

## Theory and Development of Magnetic Flux Leakage Sensor for Flaws Detection: A Review

Nor Afandi Sharif

*Instrument, Automation and Control Section,  
Electrical Engineering Department, German Malaysian Institute,*

Rizauddin Ramli\*

*Centre for Materials Engineering and Smart Manufacturing (MERCU),  
Faculty of Engineering and Built Environment, Universiti Kebangsaan Malaysia,*

Mohd Zaki Nuawi

*Centre for Integrated Design for Advanced Mechanical System (PRISMA),  
Faculty of Engineering and Built Environment, Universiti Kebangsaan Malaysia,*

Abdullah Zawawi Mohamed

*Facilities of Future, PETRONAS Research Sdn. Bhd.*

*\*Corresponding author: rizauddin@ukm.edu.my*

*Received 21 October 2020, Received in revised form 14 February 2020*

*Accepted 19 May 2020, Available online 30 August 2020*

### ABSTRACT

*This paper presents a comprehensive review of the development of magnetic flux leakage (MFL) applied by the researcher to improve existing methodology and evaluation techniques in MFL sensor development for corrosion detection in Above Storage Tanks (ASTs). MFL plays an important role in Non-Destructive (NDT) testing to detect crack and corrosion in ferromagnetic material. The demand for more reliable MFL tools and signal acquisition increase as it has a direct impact on structure integrity and can lead to major catastrophic upon questionable signal analysis. The accuracy of the MFL signal is crucial in validating the proposed method used in MFL sensor development. This is because the size, cost, efficiency, and reliability of the overall MFL system for NDT applications primarily depend on signal acquisition as a qualitative measure in producing a reliable analysis. Therefore, the selection of appropriate tools and methodology plays a major role in determining the overall performance of the system. This paper also discusses the advantages and disadvantages of major types of MFL sensors used in NDT based on the working principle and sensitivity on the abrupt signal acquisition. The application of the Artificial Neural Network (ANN) and Finite Element Method (FEM) also discussed to identify the impact on the credibility of the MFL signal.*

*Keywords: Magnetic flux leakage; non-destructive test; artificial neural network; finite element method*

### INTRODUCTION

The non-destructive testing technique is widely used in oil and gas (O&G) for validating risks specifically in specifically in ASTs, offshore structure and piping. (Cameron 2006; Ali and Saeedreza 2009; Kim et al. 2012). According to Willcox and Downes (2000), NDT is complementary to another inspection method as one of the crucial components in Quality control. The application of NDT in testing material is only permitted on the surfaces of the internal defect or metallurgical condition without any physical interference on the integrity of the affected area. There are many varieties of NDT technique used in industries, which largely depends on the methods of their applications (Dong et al. 2015; Helal et al. 2015).

Therefore, determining the quality and integrity of the material is the main purpose on NDT without affecting the capability to perform their intentional functions. In order to select the suitable NDT technique, several basic factors need to be considered such as the product diameter, length, wall thickness, fabrication methods, types, location of potential discontinuities and specification requirements. Furthermore, extraneous variables such as a scratch and oxidation that might cause a rejectable indication, even though the product is acceptable is also an important aspect (Göktepe 2013; Kollar, Setnicka, and Zubal 2016; Liying et al. 2012).

The emerging technology in NDT has triggered a challenge for the new researchers on meeting the demand of more rapid and accurate data requisition, which saw

them progressively developing a modern method to increase its reliability. Several NDT processes such as ultrasonic, radiographic, Magnetic Flux Leakage (MFL) and Eddy currents are among few of NDT method uses to investigate large structure, piping and tank (Saavedra and Prada 2014). Currently, petroleum and chemical industries are the main sectors which employ a tank bottom as a storage before the secondary process can be established. Most of the storage tanks are built on top of the ground and exposed to the external environment such as humidity and physical damages (Kim et al. 2012). As a result, it will lead to the inter-granular attack and as a result cause severe corrosion and deformation on the tank structure. A fatal accident such as an explosion and major leaking will occur because of a small defect on the tank bottom. Usually, the storage tanks in petroleum refineries and heavy industries stores hazardous and flammable chemical. Hence, a minor defect may result a catastrophic accident in term of casualties, production interruption and property loss (Chang and Lin 2006) oil terminals or storage. Fire and explosion account for 85% of the accidents. There were 80 accidents (33%).

Among all the NDT methods, the MFL inspection is one of the most reliable methods in oil and gas industries in producing a credible and prompt result and analysis (Kandroodi, Araabi, and Ahmadabadi 2013; Salama, Nestleroth, and Maes 2016). It has been used as early as 1868 by Institute of Naval Architecture in England in inspecting a cannon tube with compass. The theories behind the MFL area inspection are similar to the principle of Magnetic Particle Inspection (MPI) except for the sensor used between these two methods. The assessment of MFL technique is depended on evaluating the surface of the specimen which magnetised near to the saturation point before the specimen condition can be viewed based on measuring the magnetic leakage field (Tehranchi, Ranjbaran, and Eftekhari 2011). The MFL sensor detects volumetric changes of the leakage field on the corrosion spot (Niese, Yashan, and Willems 2008). According to Mix (2005) the permeability of magnetized pieces changed drastically, and leakage flux will emanate from the discontinuity. Hence, by measuring the intensity of the flux leakage, severity and condition of the defect can be determined. Pipe, rod, storage tank plates are the types of ferromagnetic parts that have been widely tested by MFL. In general, there are two types of defects existing in the service of the storage tank which are the corrosion and groove. Therefore, it is important to classify the pattern of the defect in order to evaluate the safety of the components (Wu, Xu, and Wang 2010).

#### METHODOLOGY

This paper addressed a review of previous research related to the theory and development of MFL sensor in plate and pipe detection in NDT. However, issue related to different kinds of sensors in MFL signal is not considered in this paper.

All the papers in the research and commercialization stages were collected from SCOPUS, the SCI web and company websites, to which the searches were limited to the period between the years of 1999 to 2016.

#### TYPES OF MFL SENSORS

There are many types of MFL sensors in magnetic signal detection such as hall sensor, superconducting quantum interference device (SQUID) and giant magnet resistance (GMR) (Krause and Kreuzbruck 2002) (Sophian, Tian, and Zairi 2006; Perin et al. 2017). The mechanism of hall affect sensor is by detecting the change of magnetic field and convert into electrical signal by processing a raw data into voltage (Ma, He, and Chen 2015). By using Hall component's sensor, defect information can be acquired by catching the faulty of leakage and process the electrical signal transformed from the magnetic field. Magnetic field distribute homogenously by passing the ferromagnetic material in the absence of defect.

If the sensor detects the presence of the imperfection on the surface of the material, the magnetic field passing this area will be distorted. As a result, the resistance around the defect will increase and expose the magnetic leakage around the defective area (Yilai et al. 2013). There also Hall sensor has been proved by having a high sensitivity in detecting defect in ferro magnetic material using direct current (DC) as a excitation (Kosmas et al. 2005). The hall voltage can be represented as:

$$V_h = \frac{IB}{neb} \quad (1)$$

Where  $V_h$ ,  $I$ ,  $B$ ,  $ne$  and  $b$  represent the Hall Voltage, several sensors in MFL testing have been introduced to the NDE (Non-Destructive Evaluation) that not been mentioned on this review such as fluxgate (Izgi et al. 2014; Can et al. 2015; Zhaoming et al. 2015), Giant Magneto Impedance (GMI) (Vacher, Alves, and Gilles-Pascaud 2007) (Dehui et al. 2017) and Stress Impedance (SI) (Mohri et al. 2001; Bayri and Atalay 2004). Table 1.0 show the tabulation of MFL types sensor for hall sensor, GMR, flux gate and SI sensor.

#### HALL EFFECT SENSOR

Hall sensor is produced according to the Hall-effect principle by embedded a thin electric conductor in sensing a magnetic field fluctuation in a ferromagnetic material (Kim and Park 2014; Ben Gur et al. 2017). An electrical current will flow through the strip when the magnetic field is perpendicular to the thin strip of conducting material as per shown in figure 1 (Clark 2004; Parker Compumotor Division Hannifin Corporation 2000).

impose current, magnetic induction intensity, Hall element sensitivity and the thickness of the hall element

TABLE 1. Magnetic sensor comparison (Mohri et al. 2002)

Sensor	Head length	Resolution	Response speed	Power consumption
Hall sensor	10–100 $\mu\text{m}$	0.5 Oe/ $\pm 1$ kOe	1 MHz	10 mW
GMR sensor	10–100 $\mu\text{m}$	0.01 Oe/ $\pm 20$ Oe	1 MHz	10 mW
Fluxgate	10–20 mm	1 $\mu\text{Oe}/\pm 3$ Oe	5 kHz	1 W
SI sensor	1–2 mm	0.1 Gal/30 Gal	10 kHz	5 mW

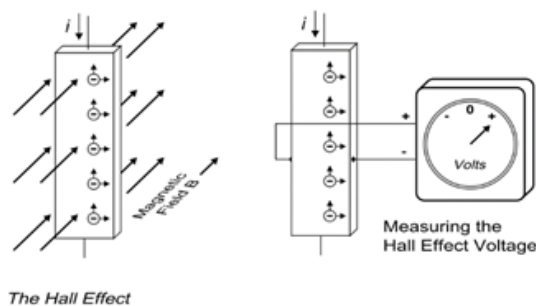

FIGURE 1. the magnetic field flow through the conductive strip (Parker Compumotor Division Hannifin Corporation 2000)

(Lijian et al. 2009). By substituting the Hall element sensitivity,  $K_h = (\text{neb})^{-1}$  in to equation 1, the equation as follow:

$$B = \frac{V_h K_h}{I} \quad (2)$$

Equation 2 show the linear relationship between the magnetic flux density and the hall voltage. The output voltage of the sensor is directly proportional with the flex density. The sensitivity of the hall sensor base silicon is 1mV/mT for a 1mA current and hall base sensor Indium arsenide InAs typically, 2 mV/mT. Sensitivity of the hall sensor also can be increase by 5 mV/mT with thin film of Indium Antimonide InSb (Ripka and Janosek 2010). The frequency sensitivity for the hall sensor is range from near DC up to 100 kHz (Park et al. 2009) with high resolution contribute to higher sensitivity with minimal power consumption.

An early work was done by Clauzon et al. (1999) integrating hall probe with eddy current in characterizing a defect under different depth and compared with Finite Element Analysis (FEA). In the observation of the study, there a difficulty in finding the correlation between signal characterization and the flaw. In 2008, Chen et al. (2008) including peak point, frequency analysis, and statistical methods such as principal component analysis (PCA) studied a defect classification by integrating Pulse Eddy Current (PEC) which has a pulse excitation providing big frequency information and hall-effect device. The result show more accurate 3-dimensional (3D) defect classification compare to the conventional method. A more recent study by Le et al. (2013) validated an integration of Dipole Model Method (MDM) using 1024 units of hall-sensor in arrayed using alternating current (AC) in estimating the shape and volume of the crack. The time in estimating the crack is proved to be faster and reliable compared to the conventional method by eliminating off-line analysis method.

#### SUPERCONDUCTING QUANTUM INTERFERENCE DEVICE (SQUID)

SQUID sensor known to have an outstanding sensitivity in detecting signal frequency between near dc and low MHz range (Braginski and Krause 2000; Kreutzbruck et al. 2001; Maze et al. 2008) at a distance of 10 nm, the spin of a single electron produces a magnetic field of about 1  $\mu\text{T}$ , and the corresponding field from a single proton is a few nanoteslas. A sensor able to detect such magnetic fields with nanometre spatial resolution would enable powerful applications, ranging from the detection of magnetic resonance signals from individual electron or nuclear spins in complex biological molecules to readout of classical or quantum bits of information encoded in an electron or nuclear spin memory. Here we experimentally demonstrate an approach to such nanoscale magnetic sensing, using coherent manipulation of an individual electronic spin qubit associated with a nitrogen-vacancy impurity in diamond at room temperature. Using an ultra-pure diamond sample, we achieve detection of 3 nT magnetic fields at kilohertz frequencies after 100 s of averaging. In addition, we demonstrate a sensitivity of 0.5  $\mu\text{T Hz}^{-1/2}$ . An experiment done by Faley et al. (1999) in analyzed a spectral density of the SQUID signal show a significant decrease of noise value especially in the strong magnetic field illustrate in figure 2. The sensor is very useful in detecting a high conductivity material with a deeper defect allocation due to its sensitivity under a low frequency. Krause et al. (2002) demonstrate a defect scanning using four High Temperature Superconductor (HTS) Direct Current (DC) SQUID that can be operated in a strong magnetic field. The experiment conclude that SQUID has a very excellent performance in detecting a very deep fault. In contrary, in order to critical temperature, a superconductor in a SQUID has to be cooled off constantly to gain it zero resistance (Lascialfari et al. 2002).

The main element in the SQUID sensor are the superconducting loop and Radio Frequency (RF) SQUIDS

(Zhang et al. 2002) or two DC SQUIDs also known as Josephson junction (Makhlin, Schön, and Shnirman 2001). The circuit diagram of a dc-SQUID sensor comprises of flux transformer and read out electronic (Vrba and Robinson 2002). Figure 3 show the circuit diagram of a dc-SQUID sensor comprises of flux transformer and read out electronic.

SQUID sensor has a better signal to noise ratio in comparison with a conventional method up to three orders of magnitude for crack exceeding 13 mm of thickness (Gao et al. 2015).

MAGNETORESISTANCE (MR) SENSOR

The principle magneto resistive sensor is by detecting a change in inductance caused by eddy current non-destructive evolution (NDE) in magnetic field of the specimen (Tsukada et al. 2006; Angani et al. 2016). The magnetic field will be distributed to the defect properties such as the hole or crack on the subject. The magnetic field is also known for the good capability in testing an ultra-high density magnetic recording in a field of NDE. Tsukada et al. (2011) used MFL technique in detecting a defect in spot welds by developing a megnetoresistive (MR) sensor in studying the interrelation between the strength and the magnetic measurement of the spot weld. The development of the experiment used two induction coils on both end of the yoke and MR sensor in the middle of the specimen. The output voltage is channel into lock in amplifier before the output data can be obtained.

In 2010, Atzlesberger and Zagar applied four GMR sensor in the experiment for examine a bilnd hole in ferro magnetic material. However, the sensor likely more sensitive than Anisotropic Magneto Resistor (AMR) due to

the design known to have a sensitive axis and nonsensitive axis orthogonally (Kataoka and Shinoura 2002). In the experiment, Helmholtz coil, (Lee et al. 2008) is used by positioning the sensor in the center of the coil in order to maintain a homogenous magnetic field before the defect properties can be acquire. In order to measure the magnetic flux density on the x-axis between the Helmholtz coil, the Biot-Savart's law (Basu et al. 2013; (Udri and Udri 1996) is used to determine the potential of uncertainty in normal flux distribution.

$$\vec{B} = \frac{\mu_0 IN}{2} \cdot \frac{R^2}{(R^2 + x^2)^{3/2}} \cdot e^x \tag{3}$$

Here  $\mu_0$ ,  $I$ ,  $R$  and  $N$  represent the permeability of free space, current, radius of the coils and number of turns, respectively. The sensor position which is located between of the coil can be expressed as:

$$x = \pm \frac{R}{2} \tag{4}$$

Equation 4 can be substituted in equation 3

$$\vec{B} \left( \pm \frac{R}{2} \right) = \frac{\mu_0 IN}{2} \cdot \frac{R^2}{(R^2 + x^2)^{3/2}} \cdot e^x \tag{5}$$

An experiment has been carried out by Basu et al. (2013) by demonstrating an empirical comparison of electromagnetic from the finite element based calculation and field computation using Biot-Savart Law. The field

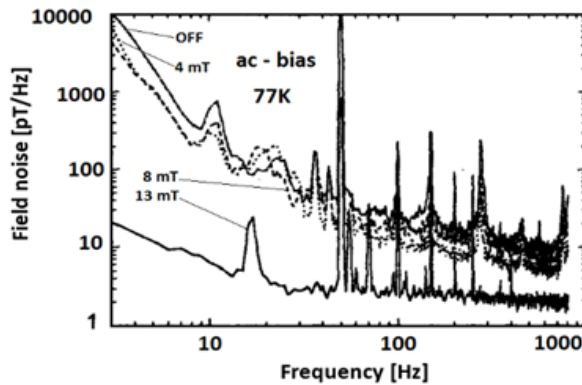

FIGURE 2. Spectral density of the SQUID sensor using magnetic field up to 13 mT (Faley et al. 1999)

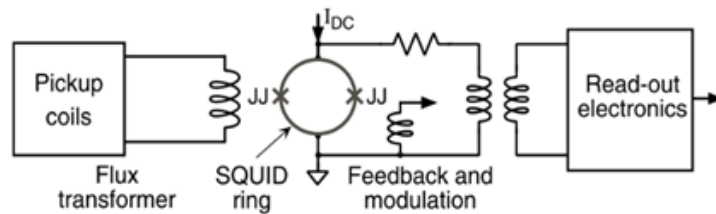

FIGURE 3. Dc-SQUID circuit diagram interrupted by two Josephson junctions (Vrba and Robinson 2002)

computation is important in determining the magnetic field of a current carrying conductor at any point to ensure the homogeneous condition for the sensor before the measured subject can be acquired.

#### PRINCIPLE AND INFLUENCE PARAMETER IN MFL DETECTION

The early work by Sauderson et al. (1988) proposed the MFL inspection for ASTs because of its advantage of being able to cover a large area speedily. At that time, the standard procedure in NDT is by the ultrasonic method which was more tedious and took long time. (Qi 2007) then explained the advantages of MFL technique for the signal analysis which revealed the correlation between the width of the amplitude of the signal and the defect. It indicates that the MFL signal amplitude varies depend to the width and length of the defect.

Furthermore, he also found that there is a complex relationship that interleaves between the variation in of three defect geometries, i.e., width, length and depth of the defects. The analytical function describing the relationship between width, length and signal demonstrate by Saha et al. (2010) in order to ascertain their depth. The study estimated the depth of the MFL defect in conjunction with the length and width function. Corrosion that was considered as general tended to be oversized in error by no more than 5%. However, there are still some ambiguities that can occur. The flux density of a plate in a tank wall can be magnetized using MFL devices [23]. The dynamic of a MFL is highly affected by the existence of the defect and detected by hall sensor (Amineh et al. 2008); Mukhopadhyay and Srivastava,

2000). According to Wang et al. (2017), the detection of the signal in MFL does not need a pre-processing. On line detection can easily carry out by implementing high degree of automation. There are several types of defects that can be detected by Magnetic flux leakage for example corrosion pitting, external surface and surface defect (Pearson n.d.).

Both circumference and axial direction can be detected by the MFL and it is the most widely used method on ASTs for locating defect on the tank floor, although it is sensitive by other factor (Chen et al. 2009; Neil R Pearson et al. 2012). The life of the tank can be increased by repairing the defect includes replacing the entire tank floor (Pearson et al. 2012). Base on the prevailing damage, individual damaged also can be repaired by welding plates. Product containing impurities in the tank could be the cause of the defect of the tank floor and the reaction between soil and environment is the cause of a defect on the bottom to the tank (Mason et al. 2009). Mandache and Clapham (2003) stated that the direct (forward) approach on the main geometry identification which comprises three steps, which are establishing MFL runs, inspection and analysis of the result. The MFL sensor detects volumetric changes within the leakage field at the corrosion spot (Ming 2004; Mandal and Atherton 1999). Hence, by measuring the intensity of the flux leakage, the severity of the defect can be determined. Figure 4 the basic principle of hall effect sensor and its connection. The MFL signal obtained from the typical axial component. The defect of the test piece is detected by measuring the magnetic leakage which making a detour under the defect when magnetic flux passes through the detected region (Sharif et al. 2020).

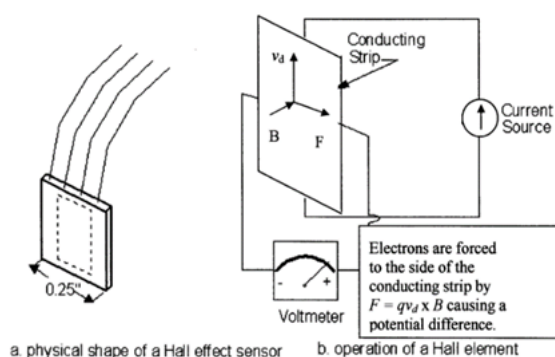

FIGURE 4. Hall effect sensor and the principle of operation (Ming 2004)

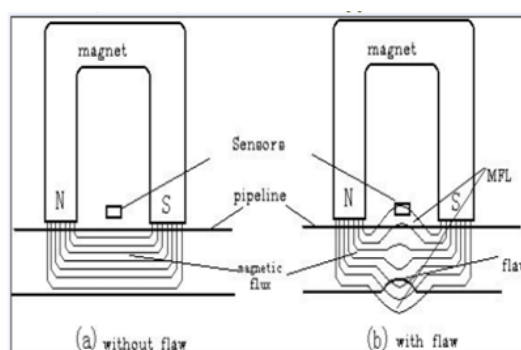

FIGURE 5. Principle on the MFL signal detection (Nagu 2013)

Figure 5 shows two conditions of MFL sensor in detecting up presence of defect on the test piece. It shows the correlation of the width, amplitude and depth to the defect signal. Both width and amplitude of the signal are proportional to the defect length (axial dimension) but the depth of the defect also affecting the amplitude of the signal (Nagu 2013).

#### DEFECT GEOMETRIES IN MFL SIGNAL

Guoguang (2010) explained the defect geometry parameters (depth, width and length) in a relationship between MFL signal features. The vertical component of the defect will not be produced by broad and shallow defects and same goes with the defect that is parallel to the magnetic field. In case of tubes, rods and bars, the longitudinal defect is more easily to be detected with the circular magnetic fields (Li, Wilson, and Tian 2007). The magnetic field will leak out from the material if there is any local gradient and geometrical discontinuity in magnetic permeability when the magnetic field applied to a ferromagnetic material. The three geometric components (radial, axial and circumferential) that also can be regarded as a vector are the main component of MFL signal (Dutta et al. 2009). In order to achieve a higher defect sizing capability in PIGs, tools for pipeline inspection have evolved into three dimensions. Typically, only defect geometry that is parallel to the pipeline axis namely axial is being measured (Kopp and Willems 2013). Most of the work does not relate with three dimensions to Above Storage Tanks (ASTs) except for one exception is Song et al. 2007) who optimizing MFL inspection tools for ASTs using three-dimensional finite-element modelling. Qingshan et al. (2011) illustrated three components in the natural cylindrical coordinate named as radial, axial and transverse. All MFL tools are commonly used to measure the axial field components by detecting the disruptions of magnetic field and the volume of the defects. Both traverse and radial field similarly occur when a defect is present and tends to characterize the profile of the feature.

In 2011, Guoguang and Penghui studied the defect allocation on the circumferential component in relative to the sensor spacing, magnetization level and velocity. A crack at the surface of the pipe will occur when there is a great difference of pressure, the classification is extremely hard to be seen by the naked eye because the crack is long and very narrow. Garcia (2012) further demonstrates the magnitude behaviors between a radial and axial signal. The research stated that the MFL axial signal's magnitude would be very high compared to the radial signal, and this will happen because the established MFL axial component's direction will parallel the external magnetic-field direction.

#### FEM BACKGROUND IN MFL

The Finite Element Method (FEM) based simulation is a technique of investigating the behaviors of the affected field

in the microscopic level (Li et al. 2006). It began in late 1980's in service inspection of buried pipelines (Mandal and Atherton 1999; Atherton and Daly 1987). In order to achieve an accurate result of field distribution, a full 3-D simulation is then introduced through a commercial software. The material property in FEM can be defined as a forward problem and the reconstruction of the crack shape can be defined as the inverse problem in objective to evaluate a parameter in material e.g.; size of the crack, length and depth in the particular field distribution (Li and Lowther 2010); (Tsuboi et al. 2004).

According to Tupsie et al. (2009), FEM is the is the general numerical method used for computer simulation, The advantage of FEM compared to others numerical method is the ability to handle circular geometric problem, non-linear and time dependent. It also the most suitable method in solving the issues of magnetic field effect around the transmission line caused by circular cross-section of voltage conductors. There are several software that can characterizes defect by using raw data, including ANSYS, MagNet, JSOL, COMSOL, Multiphysics, OPERA, MAXWELL, FLUX and others (Daniel and Abudhahir n.d.); Zhang et al. 2011; Singh et al. 2012). All of this software has an ability in computing electrostatics and magnetostatics elements. Harmonic and transient problems involving Eddy current can be well for most codes. There are some remarkable tools in implementation of advance function such as a robust solution or hysteresis loop of a moving conductor induction. The functionality of different tools however evolves rapidly and tend to converge (Augustyniak and Usarek 2016).

Ji et al. (2009) explained the proved of 2-D FEM is an effective method used to study MFL signal under the different material, different defect shape, magnetizing situation and so forth. However, in 2-D FEM defects are furthermore treated as a 2-D profile rather than actual 3-D geometry, and the resulting MFL signal is the single channel whereas the actual signals are multi-channel. The applications of 3D FEM are to analyze and generalize a potential formulation to the magnetic field in MFL and it also accurately modeled and detailed comparison is done for model with defect and without defect (Ting-yan, Yong-liang, and Tian-yu 2014). Through FEM, the characteristic of magnetic field intensity and distribution field can be examined. In addition, the FEM can analyses magnetic field. The simulation presented a SUS 304 steel pipe material and a coil that surround the pipe. Figure 6 show the four type of defect pattern generate by FEMM.

#### APPLICATION ON NEURAL NETWORK ON MFL DATA PROCESSING

In data mining and clustering, Neural Network (NN) is one of the important tools used as an attempt to build a system that has an ability as a human brain and be capable to learn (Lin et al. 2008). Currently, neural network was to use in the field of NDT because its ability to provide a solution

in data analysis (Singh and Chauhan 2009). Abdelgahani et al. (2011) proposed the inversion problem by using the neural Networks for the approximation the mapping from the signal to the defect space. The study points out a crucial problem in signal inversion where the defect profile is recovered from the measured signal by using and quantify the distribution of MFL and alteration of the intensity caused by addition of multiple magnetic circuits in order to identify and analyses the generated defect (Ting-yan et al. 2014). Similarly to research done by (Zakaria et al. 2010), Finite Element Method Magnetic (FEMM) is used to modelled different type of crack. In order to simulate the output in a small section of the pipeline, new properties have been entered into the software in introducing several cracks. A small displacement in the field carries an actual condition of the pipeline as a result from a disturbance of the

FEM as an initiator. In tank floor corrosion defect on ASTs, NN also being used to improve accuracy of the defect by establishing Back Propagation Neural Network (BPNN) in order to have a reliable quantitative recognition of width and depth of the defect. Defect in the ASTs can be obtained in three ways, and a lot of MFL testing signal samples are

needed in BPNN network as shown in figure 10. (Yang et al. 2009)

Figure 7 show the connection between input and output in hidden layer of BPNN where R, P, w, b, S, n, f and a represent input layer, input, weight, bias vector, neurons, input number, transfer function and output vector. There are three ways of acquiring a MFL testing signal sample of corrosion defect in ASTs in BPNN which need a lot sample.

1. The MFL testing corrosion signal must be extract in the tank floor as a sample testing. Sample taken in the process must be authentic and must maintain close to actual situation of MFL testing corrosion of the tank floor.
2. Artificial neural network is use as precast corrosion defect in the tank floor, a collection of MFL testing signal is recorded in the corrosion database, external factors such as experimental condition and human factor is largely affected.
3. Establishing a finite element as a simulation process to differentiate with the MFL signal collected from the sample of corrosion defect in the tank floor. The

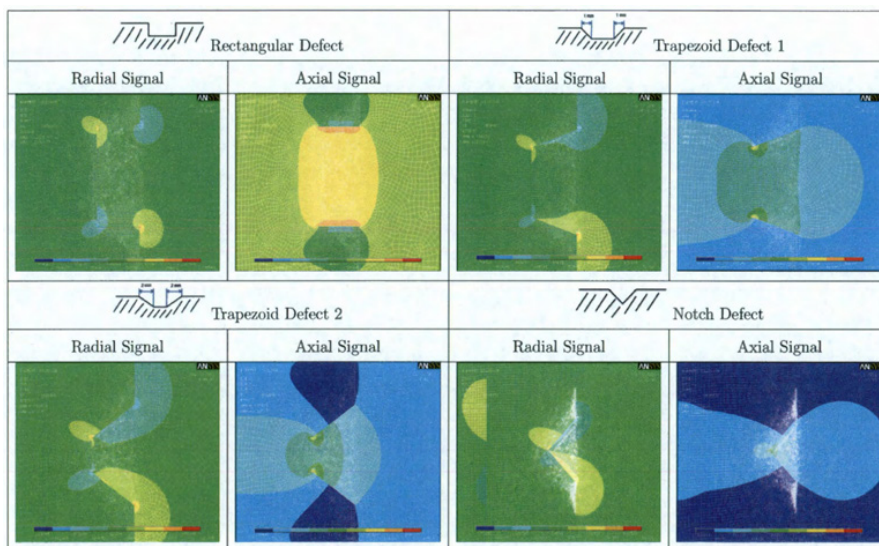

FIGURE 6. Four Defects - Finite Element Analysis MFL Displayed Solution (Garcia 2012)

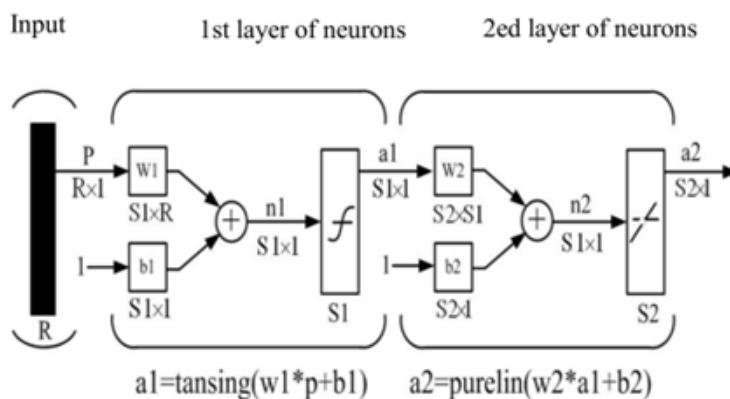

FIGURE 7. BPNN with hidden layer (Yang et al. 2009)

interference of numerous detection signal can be avoided and it can solve the problem that the sample number can't meet.

Chen et al. (2015) discussed on iterative neural network application on the defect inversion from a MFL signal. There are two kinds of method in solving inverse MFL problems, including model-based iterative method and non-model-based direct method. A non-model based direct method is used to established the relationship between corresponding defect and MFL signal through NN or other tools Zhang et al. (2009). Even though the method is advantageous to make a rapid inversion, the prediction of defect profile is not accurate due to lacking of continuous depended of measured MFL signals on defect parameters in non-unique condition. The model-based method on the contrary, use forward model to solve the well-behaved forward problem iteratively in a feedback loop in predicting the MFL signals by begin the algorithm with an initial estimation of the defect and solves the forward problem (Ramuhalli et al. 2003). The measured and predicted error can be minimized iteratively by updating the defect profile based on gradient-based or optimization methods (Wenhua and Peiwen 2005).

#### CONCLUSION

This paper reviews the concept and developments of MFL inspection with regard to principle and influence in detection, defect geometries, FEM and the application of Neural Network in data processing. Several issues need to be improved on such as a noise, defect profiling, development cost, forward model and inverse model. There are a lot of researches has been conducted on MFL signal analysis. However, there are only a few researches emended comprehensive statistical analysis as an inverse model. There is still room for the improvement and optimization of all these issues.

#### DECLARATION OF COMPETING INTEREST

None.

#### ACKNOWLEDGEMENT

This work was supported by the National University of Malaysia (UKM) under research grant INDUSTRI-2013-010.

#### REFERENCES

- Abdelgahani, Ayad, Benhamida Farid, Bendaoud Abdelber, Bihan Yann Le, and Bensetti Mohamed. 2011. Solution of inverse problems in electromagnetic NDT using neural networks. *PRZEGLĄD ELEKTROTECHNICZNY (Electrical Review)* 87(9):330–33.
- Ali, Sadr and Ehteram Saeedreza. 2009. Intelligent MFL defect detection algorithm equipped by linear discriminate analysis. *IJCNC: International Journal of Computer Networks & Communications* 5(June):1–21.
- Amineh, R. K., S. Koziel, N. K. Nikolova, J. W. Bandler, and J. P. Reilly. 2008. A space mapping methodology for defect characterization from magnetic flux leakage measurements. *IEEE Transactions on Magnetics* 44(8):2058–65.
- Angani, Chandra Sekhar, Helena Geirinhas Ramos, Artur Lopes Ribeiro, and Tiago Jorge Rocha. 2016. Evaluation of transient eddy current oscillations response for thickness measurement of stainless steel plate. *Measurement: Journal of the International Measurement Confederation* 90:59–63.
- Atherton, D. L. and M. G. Daly. 1987. Finite element calculation of magnetic flux leakage detector signals. *NDT International* 20(4):235–38.
- Atzlesberger, Johannes and Bernhard Zagar. 2010. Magnetic flux leakage measurement setup for defect detection. *Procedia Engineering* 5:1401–4.
- Augustyniak, Marek and Zbigniew Usarek. 2016. Finite element method applied in electromagnetic NDTE - A review. *Journal of Nondestructive Evaluation* 1–16.
- Basu, Shibaji, Siddhartha Shankar Pany, Partha Bannerjee, and Sabyasachi Mitra. 2013. Pulsed magnetic field measurement outside finite length solenoid: Experimental results & mathematical verification. *Journal of Electromagnetic Analysis and Applications* 2013(October): 371–78.
- Bayri, N. and S. Atalay. 2004. giant stress-impedance effect in Fe71Cr7Si 9B13 amorphous wires. *Journal of Alloys and Compounds* 381(1–2):245–49.
- Braginski, A. I. and H. Krause. 2000. Nondestructive evaluation using high-temperature SQUIDs. *Physica C* 179–83.
- Cameron, N. B. 2006. *Recommended Practice For Magnetic Flux Leakage Inspection Of Atmospheric Storage Tank Floors*.
- Can, Hava, Peter Svec, Sercan Tanriseven, Jan Bydzovsky, Cengiz Birlikseven, Hüseyin Sözeri, and Uur Topal. 2015. Optimizing the Sensing Performance of a Single-Rod Fluxgate Magnetometer Using Thin Magnetic Wires. *Measurement Science and Technology* 26(11).
- Chang, James I. and Cheng Chung Lin. 2006. A study of storage tank accidents. *Journal of Loss Prevention in the Process Industries* 19(1): 51–59.
- Chen, Junjie, Songling Huang, and Wei Zhao. 2015. Three-dimensional defect inversion from magnetic flux leakage signals using iterative neural network. *IET Science, Measurement & Technology* 9(August 2014):418–26.
- Chen, Liang, Xing Li, Xun-bo Li, and Zuo-ying Huang. 2009. Signal extraction using ensemble empirical mode decomposition and sparsity in pipeline magnetic flux leakage nondestructive evaluation. *Review of Scientific Instruments* 80(2): 025105.
- Chen, Tianlu, Gui Yun Tian, Ali Sophian, and Pei Wen Que. 2008. Feature extraction and selection for defect classification of pulsed eddy current NDT. *NDT and E International* 41(6):467–76.
- Clark, Robin. 2004. Rail flaw detection: Overview and needs for future developments. *NDT and E International* 37(2):111–18.
- Clauzon, T., F. Thollon, and A. Nicolas. 1999. Flaws Characterization with Pulsed Eddy Currents N.D.T. *IEEE TRANSACTIONS ON MAGNETICS* 35(3):1873–76.



- Daniel, Jackson and R. Mohanagayathrianda Abudhahir. n.d. *Characterization of Defects in Magnetic Flux Leakage (MFL) Images Using Wavelet Transform and Neural Network*.
- Dehui, Wu, Su Lingxin, Wang Xiaohong, and Liu Zhitian. 2017. A novel non-destructive testing method by measuring the change rate of magnetic flux leakage. *Journal of Nondestructive Evaluation* 36(2): 24.
- Dong, Jingwei, Qijian Wu, Wenwen Jiang, and Qi Xu. 2015. The Review of new NDT methods of metal material fatigue monitoring. *International Journal of Hybrid Information Technology* 8(8):225–32.
- Dutta, Sushant M., Fathi H. Ghorbel, and Roderic K. Stanley. 2009. Dipole modeling of magnetic flux leakage. *IEEE TRANSACTIONS ON MAGNETICS* 45(4): 1959–65.
- Faley, M., U. Poppe, and K. Urban. 1999. Operation of HTS De-SQUID sensors in high magnetic fields. *IEEE Transactions On Applied Superconductivity* 9(2):3386–91.
- Gao, P., C. Wang, Y. Li, and Z. Cong. 2015. Electromagnetic and eddy current NDT in weld inspection: A review. *Insight: Non-Destructive Testing and Condition Monitoring* 57(6):337–45.
- Garcia, D. & Trvino, A. 2012. *Modelling and Interpretation of Magnetic Flux Leakage*. RICE University, Houston, Texas.
- Göktepe, M. 2013. Investigation of bx and by components of the magnetic flux leakage in ferromagnetic laminated sample. *Advances in Materials Science and Engineering* 2013.
- Guoguang, Zhang. 2010. Defect Quantitative Recognition Technology of Circumferential Magnetic Flux Leakage Inspection in Pipeline. *International Conference on Computer Application and System Modeling (ICCA SM)* (Iccasm): 311–14.
- Guoguang, Zhang and Li Penghui. 2011. Signal processing technology of circumferential magnetic flux leakage inspection in pipeline. *Third International Conference on Measuring Technology and Mechatronics Automation Signal* (5):5–8.
- Ben Gur, Leah, Einat Tirosh, Amir Segal, Gil Markovich, and Alexander Gerber. 2017. Extraordinary hall-effect in colloidal magnetic nanoparticle films. *Journal of Magnetism and Magnetic Materials* 426(November 2016): 178–82.
- Helal, J., M. Sofi, and P. Mendis. 2015. Non-destructive testing of concrete: A review of methods. *Electronic Journal of Structural Engineering* 14(1):97–105.
- Izgi, T., M. Goktepe, N. Bayri, V. S. Kolat, and S. Atalay. 2014. Crack detection using fluxgate magnetic field sensor. *Acta Physica Polonica A* 125(2): 211–13.
- Ji, Fengzhu, Changlong Wang, Shiyu Sun, and Weiguo Wang. 2009. Application of 3-D FEM in the simulation analysis for MFL signals. *Insight: Non-Destructive Testing and Condition Monitoring* 51(1):32–35.
- Kandroodi, Mojtaba Rostami, Babak Nadjar Araabi, and Majid Nili Ahmadabadi. 2013. *Detection of Natural Gas Pipeline Defects Using Magnetic Flux Leakage Measurements*.
- Kataoka, Yasuhiro and Osamu Shinoura. 2002. 65.2: Leakage flux testing using a GMR line sensor and a rotating magnetic field. *IEEE* 800–803.
- Kim, Hui Min and Gwan Soo Park. 2014. A study on the estimation of the shapes of axially oriented cracks in CMFL type NDT system. *IEEE Transactions on Magnetics* 50(2):18–21.
- Kim, Hui Min, Yong Woo Rho, Hui Ryong Yoo, Sung Ho Cho, Dong Kyu Kim, Sung Ja Koo, and Gwan Soo Park. 2012. A Study on the measurement of axial cracks in the magnetic flux leakage NDT system. *IEEE International Conference on Automation Science and Engineering* 624–29.
- Kollar, Mojmir, Vit. Setnicka, and Rudolf Zubal. 2016. *Scanning And Data Acquisition Tools For Mfl Testing*.
- Kopp, Gerhard and Herbert Willems. 2013. “Sizing Limits of Metal Loss Anomalies Using Tri-Axial MFL Measurements: A Model Study.” *NDT and E International* 55:75–81.
- Kosmas, K., Ch Sargentis, D. Tsamakis, and E. Hristoforou. 2005. “Non-Destructive Evaluation of Magnetic Metallic Materials Using Hall Sensors.” *Journal of Materials Processing Technology* 161(1-2 SPEC. ISS.):359–62.
- Krause, H. and M. Kreuzbruck. 2002. “Recent Developments in SQUID NDE.” *Physica C* 368:70–79.
- Krause, H., W. Wolf, W. Glaas, E. Zimmermann, and M. I. Faley. 2002. “SQUID Array for Magnetic Inspection of Prestressed Concrete Bridges.” *Physica C* 368:91–95.
- Kreutzbruck, M. v., K. Allweins, T. Ruhl, M. Muck, C. Heiden, H. J. Krause, and R. Hohmann. 2001. “Defect Detection and Classification Using a SQUID Based Multiple Frequency.” *IEEE TRANSACTIONS ON APPLIED SUPERCONDUCTIVITY* 11(1):1032–37.
- Lascialfari, A., T. Mishonov, A. Rigamonti, P. Tedesco, and A. Varlamov. 2002. “Superconducting Diamagnetic Fluctuations in MgB<sub>2</sub>.” *PHYSICAL REVIEW B* 65(0):4–7.
- Le, Minhhuy, Jinyi Lee, Jongwoo Jun, Jungmin Kim, Sangman Moh, and Kisu Shin. 2013. “Hall Sensor Array Based Validation of Estimation of Crack Size in Metals Using Magnetic Dipole Models.” *NDT and E International* 53:18–25.
- Lee, Jinyi, Jiseong Hwang, Jongwoo Jun, and Seho Choi. 2008. “Nondestructive Testing and Crack Evaluation of Ferromagnetic Material by Using the Linearly Integrated Hall Sensor Array.” *Journal of Mechanical Science and Technology* 22(12):2310–17.
- Li, M. and D. A. Lowther. 2010. “The Application of Topological Gradients to Defect Identification in Magnetic Flux Leakage-Type NDT.” 46(8):3221–24.
- Li, Yong, Gui Yun Tian, and Steve Ward. 2006. “Numerical Simulation on Magnetic Flux Leakage Evaluation at High Speed.” *NDT & E International* 39(5):367–73.
- Li, Yong, John Wilson, and Gui Yun Tian. 2007. “Experiment and Simulation Study of 3D Magnetic Field Sensing for Magnetic Flux Leakage Defect Characterisation.” *NDT & E International* 40(2):179–84.
- Lijian, Yang, Liu Gang, Gao Songwei, and A. Coil. 2009. “Sensor Development and Application on the Oil-Gas Pipeline Magnetic Flux Leakage Detection.” *The Ninth International Conference on Electronic Measurement & Instruments* 876–78.
- Lin, Shih Wei, Kuo Ching Ying, Shih Chieh Chen, and Zne Jung Lee. 2008. “Particle Swarm Optimization for Parameter Determination and Feature Selection of Support Vector Machines.” *Expert Systems with Applications* 35(4):1817–24.
- Liyong, S. U. N., L. I. Yibo, S. U. N. Libo, and L. I. Lingge. 2012. “Comparison of Magnetic Flux Leakage (MFL) and

- Acoustic Emission (AE) Techniques in Corrosion Inspection for Pressure Pipelines." *Proceedings of the 31st Chinese Conference* 5375–78.
- Ma, Yilai, Renyang He, and Jinzhong Chen. 2015. "A Method for Improving SNR of Drill Pipe Leakage Flux Testing Signals by Means of Magnetic Concentrating Effect." *IEEE Transactions on Magnetics* 51(9).
- Makhlin, Y., G. Schön, and A. Shnirman. 2001. "Quantum-State Engineering with Josephson-Junction Devices." *Rev. Mod. Phys.* 73(April):357.
- Mandache, Catalin and Lynann Clapham. 2003. "A Model for Magnetic Flux Leakage Signal." *JOURNAL OF PHYSICS D: APPLIED PHYSICS* 2427.
- Mandal, K. and D. L. Atherton. 1999. "A Study of Magnetic Flux-Leakage Signals." *Journal of Physics D: Applied Physics* 31:3211–17.
- Mason, John S. D., Neil Pearson, and Alicia Romero Ramirez. 2009. "Experimental Study to Differentiate Between Top and Bottom Defects for MFL Tank Floor Inspections." *NDT&E International* 42:16–21.
- Maze, J. R., P. L. Stanwix, J. S. Hodges, S. Hong, J. M. Taylor, P. Cappellaro, L. Jiang, M. V. Gurudev Dutt, E. Togan, A. S. Zibrov, A. Yacoby, R. L. Walsworth, and M. D. Lukin. 2008. "Nanoscale Magnetic Sensing With An Individual Electronic Spin In Diamond." *Nature* 455(7213):644–47.
- Ming, W. Toh. 2004. "Design and Construction of Magnetic Flux Leakage Inspection System for Ferromagnetic Material."
- Mix, Paul E. 2005. *Introduction To Nondestructive Testing: A Training Guide*. Second Edi. Canada: A JOHN WILEY & SONS, INC., PUBLICATION.
- Mohri, K., T. Uchiyama, L. P. Shen, C. M. Cai, and L. V. Panina. 2001. "Sensitive Micro Magnetic Sensor Family Utilizing Magneto-Impedance (MI) and Stress-Impedance (SI) Effects for Intelligent Measurements and Controls." *Sensors and Actuators A: Physical* 91(1–2):85–90.
- Mohri, K., T. Uchiyama, L. P. Shen, C. M. Cai, and L. V. Panina. 2002. "Amorphous Wire and CMOS IC-Based Sensitive Micro-Magnetic Sensors (MI Sensor and SI Sensor) for Intelligent Measurements and Controls." *Journal of Magnetism and Magnetic Materials* 249(1–2):351–56.
- Mukhopadhyay, S. and G. P. Srivastava. 2000. "Characterisation of Metal Loss Defects from Magnetic Flux Leakage Signals with Discrete Wavelet Transform." *NDT and E International* 33(1):57–65.
- Nagu, S. 2013. "Finite Element Modeling of Magnetic Flux Leakage Technique in Plates with Defect and without Defect." *International Journal of Modern Engineering Research* 3:3452–55.
- Niese, Frank, Andre Yashan, and Herbert Willems. 2008. "Wall Thickness Measurement Sensor for Pipeline Inspection Using EMAT Technology in Combination with Pulsed Eddy Current and MFL." *Non-Destructive Testing, Australia* 3(45):84–87.
- Park, D. G., C. S. Angani, G. D. Kim, C. G. Kim, and Y. M. Cheong. 2009. "Evaluation of Pulsed Eddy Current Response and Detection of the Thickness Variation in the Stainless Steel." *IEEE Transactions on Magnetics* 45(10):3893–96.
- Parker Compumotor Division Hannifin Corporation. 2000. "Hall Effect Sensors." Pp. 107–18 in *Compumotor - Servo Drive User Guide*.
- Pearson, N. R., J. S. D. Mason, and R. H. Priewald. 2012. "The Influence of Maintenance on the Life Cycle of Above-Ground Storage Tanks." *Insight: Non-Destructive Testing and Condition Monitoring* 54(6):311–15.
- Pearson, Neil. n.d. *Discrimination of Top and Bottom Discontinuities with MFL and the Surface Topology Air-Gap Reluctance System (STARS)*.
- Pearson, Neil R, Matthew A. Boat, Robin H. Priewald, Matthew J. Pate, and John S. D. Mason. 2012. "A Study Of MFL Signals From A Spectrum of Defect Geometries." *18th World Conference on Nondestructive Testing* (April):16–20.
- Perin, Deniz, Aykut Ilgaz, Mustafa Göktepe, D Perin, A Ilgaz, Göktepe M. Mass, Eng Struct, Deniz Perin, Aykut Ilgaz, and Mustafa Göktepe. 2017. *Mass Effect on Magnetic Flux Behavior*.
- Qi, Jiang. 2007. "Experimental Study of Interference Factors and Simulation on Oil-Gas Pipeline Magnetic Flux Leakage Density Signal." *International Conference on Mechatronics and Automation* 3652–56.
- Qingshan, Feng, Jeff Sutherland, Bill Gu, Yao Wei, and Cui Tao. 2011. "Evolution of Triax Magnetic Flux Leakage Inspection For Mitigation Of Spiral Weld Anomalies." *6th Pipeline Technology Conference*.
- Ramuhalli, Pradeep, Lalita Udpa, and Satish S. Udpa. 2003. "Neural Network-Based Inversion Algorithms in Magnetic Flux Leakage Nondestructive Evaluation." *Journal of Applied Physics* 93(10 3):8274–76.
- Ripka, P. and M. Janosek. 2010. "Advances in Magnetic Field Sensors." *IEEE Sensors Journal* 10(6):1108–16.
- Saavedra, C. F. Jaimes and S. Roa Prada. 2014. *Sensitivity Analysis of a Magnetic Circuit for Non-Destructive Testing by the Magnetic Flux Leakage Technique*.
- Saha, S., S. Mukhopadhyay, U. Mahapatra, S. Bhattacharya, and G. P. Srivastava. 2010. "Empirical Structure for Characterizing Metal Loss Defects from Radial Magnetic Flux Leakage Signal." *NDT and E International* 43(6):507–12.
- Salama, Mamdouh M., Bruce J. Nestleroth, and Marc A. Maes. 2016. "Characterization Of The Accuracy Of The Mfl Pipeline Inspection Tools." *Proceedings of the ASME 2012 31st International Conference on Ocean, Offshore and Arctic Engineering* 1–5.
- Sauderson, D. H. 1988. "The MFE Tank Floor Scanner - a Case History." *IEE Colloquium on Non-Destructive Evaluation* 1.
- Sharif, Nor Afandi, Rizauddin Ramli, Mohd Zaki Nuawi, and Khairulbadri Ahmad. 2020. "Characterization of Defect for Magnetic Flux Leakage in Non-Destructive Test Using I-Kaz TM." (5):881–86.
- Singh, W. Sharatchandra, B. P. C. Rao, S. Thirunavukkarasu, and T. Jayakumar. 2012. "Flexible GMR Sensor Array for Magnetic Flux Leakage Testing of Steel Track Ropes." *Journal of Sensors* 2012:1–6.
- Singh, Yashpal and Alok Singh Chauhan. 2009. "Neural Networks In Data Mining." *Journal of Theoretical and Applied Information Technology* 5(1):1–154.

- Song, Xiao-chun, Song-ling Huang, and Wei Zhao. 2007. "Optimization of the Magnetic Circuit in the MFL Inspection System for Storage-Tank Floors." *Russian Journal of Nondestructive Testing* 43(5):326–31.
- Sophian, Ali, Gui Yun Tian, and Sofiane Zairi. 2006. "Pulsed Magnetic Flux Leakage Techniques For Crack Detection And Characterisation." *Sensors and Actuators* 125:186–91.
- Tehranchi, M. M., M. Ranjbaran, and H. Eftekhari. 2011. "Double Core Giant Magneto-Impedance Sensors for the Inspection of Magnetic Flux Leakage from Metal Surface Cracks." *Sensors and Actuators, A: Physical* 170(1–2):55–61.
- Ting-yan, Gao, Yu Yong-liang, and Han Tian-yu. 2014. *The Interaction of Multiple Magnetic Circuits in Magnetic Flux Leakage (MFL) Inspection*.
- Tsuboi, H., N. Seshima, I. Sebestyen, J. Pavo, S. Gyimothy, and A. Gasparics. 2004. "Transient Eddy Current Analysis of Pulsed Eddy Current Testing by Finite Element Method." *IEEE Transactions on Magnetics* 40(2):1330–33.
- Tsukada, Keiji, Toshihiko Kiwa, Tomoaki Kawata, and Yudai Ishihara. 2006. "Low-Frequency Eddy Current Imaging Using Mr Sensor Detecting Tangential Magnetic Field Components For Nondestructive Evaluation." *IEEE Transactions on Magnetics* 42(10):3315–17.
- Tsukada, Keiji, Mitsuteru Yoshioka, Toshihiko Kiwa, and Yoshinobu Hirano. 2011. "A Magnetic Flux Leakage Method Using a Magneto-resistive Sensor for Nondestructive Evaluation of Spot Welds." *NDT and E International* 44(1):101–5.
- Tupsie, S., A. Isaramongkolrak, and P. Pao-la-or. 2009. "Analysis of Electromagnetic Field Effects Using FEM for Transmission Lines Transposition." *Engineering and Technology* 3(2):870–74.
- Udri, C. and S. Udri. 1996. "Biot-Savart-Laplace Dynamical Systems." *Balkan Journal of Geometry and Its Applications*, 1(2):125–36.
- Vacher, F., F. Alves, and C. Gilles-Pascaud. 2007. "Eddy Current Nondestructive Testing with Giant Magneto-Impedance Sensor." *NDT and E International* 40(6):439–42.
- Vrba, J. and S. E. Robinson. 2002. "SQUID Sensor Array Configurations For Magnetoencephalography Applications." *Superconductor Science and Technology* 15(9).
- Wang, Yadong, Yanting Xu, Bing Wang, Shoubao Ding, Jiele Xu, and Mulin Zheng. 2017. "Research On Metal Atmospheric Storage Tank Inspection Method for Standard In China." *Proceedings of the ASME 2009 Pressure Vessels and Piping Division Conference* 1–6.
- Wenhua, Han and Q. Peiwen. 2005. "2-D Defect Reconstruction from MFL Signals Based on Genetic Optimization Algorithm." *IEEE Int. Conf. on Industrial Technology* 508–13.
- Willcox, Mark and George Downes. 2000. *A Brief Description of NDT Techniques*.
- Wu, Xinjun, Jiang Xu, and Yanling Wang. 2010. "Signal Processing Methods for Magnetic Flux Leakage Testing Based On Biospectrum." *Proceeding of European NDT Conference*.
- Yang, Zhijun, Guang Dai, Wei Li, and Yanbiao Jiang. 2009. "Research on Magnetic Flux Leakage Signals Quantity Technology of Tank Floor Corrosion Defects Based on Artificial Neural Networ." *5th International Conference on Natural Computation, ICNC 2009* 2:245–49.
- Yilai, Ma, Lin Li, Jiang Kaiwen, and Zhao Xulin. 2013. "The Application of Magnetic Shielding Effect in Drill Pipe Magnetic Leakage Flux Testing." *Fifth Conference on Measuring Technology and Mechatronics Automation* (1):1135–38.
- Zakaria, Zulkarnay, Muhammad Saiful, Badri Mansor, Aishah Hartini Jahidin, Mohd Shuhanaz, Zonar Azlan, and Ruzairi Abdul Rahim. 2010. "Simulation of Magnetic Flux Leakage (MFL) Analysis Using FEMM Software." *2010 IEEE Symposium on Industrial Electronics and Applications (ISIEA 2010)* (Isica):481–86.
- Zhang, Wei, Yi Bing Shi, and Yan Jun Li. 2011. "Magnetic Coil Parameters Design of Oil Casing Damage Detector Based on Magnetic Flux Leakage." *Proceedings of 2011 IEEE International Conference on Applied Superconductivity and Electromagnetic Devices* 50–53.
- Zhang, Y., J. Schubert, N. Wolters, M. Banzet, W. Zander, and H. J. Krause. 2002. "Substrate Resonator for HTS Rf SQUID Operation." *Physica C: Superconductivity and Its Applications* 372–376 (PART 1):282–86.
- Zhang, Yong, Zhongfu Ye, and Chong Wang. 2009. "A Fast Method for Rectangular Crack Sizes Reconstruction in Magnetic Flux Leakage Testing." *NDT and E International* 42(5):369–75.
- Zhaoming, Z., S. Taihe, Y. Runqiao, and W. Fu. 2015. "A New Approach to In-Service Coiled Tubing Improved Inspection Based Micro-Magnetic Technology." *Society of Petroleum Engineers - Coiled Tubing and Well Intervention Conference and Exhibition 2015* 1–13.