

THE IMPACT OF SPIRITUALITY AND SOCIAL RESPONSIBILITY ON ORGANIZATIONAL CITIZENSHIP BEHAVIOUR FROM THE ISLAMIC PERSPECTIVE: EMPIRICAL INVESTIGATION OF MALAYSIAN BUSINESSES

NAAIL MOHAMMED KAMIL
SEGI UNIVERSITY

MOHAMED SULAIMAN
INTERNATIONAL ISLAMIC UNIVERSITY MALAYSIA

SUGUMARAN SELLADURAI
SEGI UNIVERSITY

NADHIRA KHALID
INTERNATIONAL ISLAMIC UNIVERSITY MALAYSIA

Abstract

The phenomenon of organizational citizenship behavior (OCB) emanating from the Western value system has received enormous attention from researchers, however, the model of organizational citizenship behavior from other cross cultural or religious perspectives such as the Islamic perspective, has not been much explored. This empirical study attempts to enrich the understanding of OCB from Islamic management perspective. In view of this, Western OCB framework was studied and further enriched in light of the Islamic heritage (Qur'an and Sunnah, i.e. that Prophetic tradition of Prophet Muhammad, peace be upon him) and established the need for Taqwa serving as antecedent of citizenship behaviors from the Islamic perspective. The survey data used for this empirical research was drawn from 405 Muslim employees in business organizations in Malaysia. Principal component analysis

(i.e. PCA using SPSS version 18.0) and confirmatory factor analysis (i.e. CFA using AMOS version 18.0) of the constructs; Islamic spirituality (IS), Islamic social responsibility (ISR) and Organizational citizenship behaviour from Islamic perspective (OCBIP), were conducted. Using structural equation modeling (SEM), good fit indices led to two major findings, thus, ISR influences employees' OCBIP performance; IS does not. Several implications from the study were discussed.

Keywords: *Spirituality, social responsibility, organizational citizenship behaviour from islamic perspective (ocbip), taqwa.*

KESAN KEROHANIAN DAN TANGGUNGJAWAB SOSIAL PADA KELAKUAN KEWARGANEGARAAN ORGANISASI DARI PERSPEKTIF ISLAM (OCBIP): SIASATAN EMPIRICAL TERHADAP PERNIAGAAN MALAYSIA

Abstrak

Fenomena kelakuan kewarganegaraan organisasi yang berasal dari sistem nilai negara barat telah mendapat perhatian yang besar dari para penyelidik, walaubagaimanapun, model tingkah laku kewarganegaraan organisasi dari perspektif pelbagai budaya atau perpektif agama lain seperti perspektif Islam, masih belum banyak diterokai. Kajian empirikal ini bertujuan untuk memperkayakan lagi pemahaman berkaitan OCB dari perspektif pengurusan Islam. Oleh yang demikian, rangka kerja OCB Barat telah dikaji dan seterusnya diperkaya berdasarkan warisan Islam (Al- Quran dan Sunah, yakni Hadis Rasullullah s.a.w) dan menubuhkan keperluan takwa di dalam kewarganegaraan tingkah laku dari perspektif Islam. Data kajian yang digunapakai untuk kajian empirical ini telah dilakukan ke atas 405 pekerja Islam di organisasi perniagaan di Malaysia. Analisis Prinsipal Komponen (iaitu PCA menggunakan SPSS versi 18.0) dan Analisis Faktor Pengesahan (iaitu CFA menggunakan AMOS versi 18.0) daripada binaan; kerohanian Islam (IS), tanggungjawab social islam (ISR) dan Kelakuan Kewarganegaraan Organisasi dari perspektif Islam (OCBIP), telah dijalankan. Dengan menggunakan struktur pemodelan persamaan (SEM), kajian telah menunjukkan dua penemuan terbesar, oleh itu,

ISR mempengaruhi prestasi OCBIP pekerja, IS tidak. Beberapa implikasi daripada kajian telah dibincangkan.

Kata kunci: *Kerohanian, tanggungjawab sosial, kelakuan kewarganegaraan organisasi dari perspektif islam (ocbip), taqwa.*

INTRODUCTION

Organizational Citizenship Behavior (OCB) is defined by Organ (1988) as “individual behavior that is discretionary, not directly or explicitly recognized by the formal reward system, and that in the aggregate promotes the effective functioning of the organization” (p. 4). In the past, most research works on OCB were conducted from European and American perspectives that emanate from the western value systems since its inception in 1983 by Bateman and Organ. Although to some extent, these research works enriched the understanding of OCB and its antecedents in relation to organizational goal achievements, a recent Meta-analysis by Podsakoff, Whiting, Podsakoff and Blume (2009) after critically reviewing over 500 Western OCB studies, concluded that the Western approach of OCB research works still has not been able to sufficiently capture the salient reasons as to why OCBs occur.

In view of this, perhaps, what has not been sufficiently explored is the relations between organizational goal achievement and; (1) OCB from Islamic perspective; (2) the antecedents of OCB from Islamic perspective; (3) OCB conducted in Muslim majority companies; (4) OCB conducted on Muslim employees working in non-Muslim organizations. These are gaps for which this study attempts to narrow, thereby enriching the understanding of the OCB from Islamic perspective.

It is also worth noting that most of the research that emanate from the Western value system give very little or no consideration at all to the Islamic worldview. As held by Al-Attas (2001), the Muslim worldview is defined as “the vision of reality and truth that appears before the Muslim’s mind’s eye revealing what existence is all about; for it is the world of existence in its totality that Islam projects” (Al-Attas, p.2). This assertion by Al-Attas leads us to the belief, understanding and realization that whereas the western value systems project only the worldly affairs, the Muslim’s worldview considers not only this dunya (earthly) but also the akhirah (hereafter). Muslims believe that this world is a temporary place to live in and all good deeds are acts of worship i.e. Icbādah. These core beliefs of Islam have to be captured in all spheres of the Muslim activities including organizational behavior as is the focus of this research. This is not giving much consideration in the current status of the OCB research attempts emanating from the west. In view of this, it can be noted the OCB

concept and its antecedents as held by contemporary Western researchers do not adequately fit the Islamic worldview. This study seeks to address this research gap, by integrating Western OCB concept and the Islamic heritage (Qur'an and the Prophetic tradition) and propose an OCB from Islamic perspective (OCBIP) model which serves to represent, describes and fits the Muslim world-view.

Furthermore, there have been many arguments in contemporary literature, regarding the factors and characteristics that induce OCBs in employees (Monfared, Mousavi, Sajjadi, & Heidary, 2011; Organ, 1997). The knowledge of these factors can enhance organizational profitability and overall performance via the creation of environment or culture that will yield such factors. Although much research works have been conducted, there are insufficient studies that are conducted from Islamic perspectives (Kamil et al., 2010). Moreover, all antecedents captured by literature are relative, which is dependent on the induction of a behavior before an employee reciprocates with OCB (Blau, 1964). This study attempts to investigate the absolute OCB antecedents. Absolute here means, those antecedents with which employees and especially Muslim employees will have high propensity to exhibit OCBs in whichever organization they belong to, regardless of social, cultural or economic backgrounds.

As posited by Al-Amar (2008), there are many sources of values such as culture, society and personal experience. Religion is a fundamental element that shapes the culture and influences all components of the society. As mentioned in the Qur'an, Islam is the religion on the sight of Allah (Qur'an 3:19). For this reason, although there are many Islamic concepts that may have significant effects on an ideal Muslim's behavior, this study proposes one of the very important Islamic concepts (i.e. Taqwa) to serve as antecedent of citizenship behaviors from Islamic viewpoint.

As held by Kazmi (2004), there is the need for Middle East countries to evaluate the suitability of current management practices to find out the strengths and weaknesses. It is worthwhile to note, that although Malaysia is not in the Middle East geographically, its policies and culture are similar to those of the Middle East countries due to the fact that to some considerable extent, it adopts, maintains and holds up the Islamic belief and culture system. As posited by Hashim (2009) and Kettani (2010), Malaysia is a Muslim country, and for that the government of Malaysia has been implementing an Islamization process (Hashim, 2009) in which its ultimate goal is to infuse Islamic values throughout the society at all levels, from individual to institutional. Hashim added that the then Malaysian Prime Minister, Tun Abdullah Badawi, wants Malaysians to take pride in their cultural heritage and adopt values and attitudes, which reveal the best behavior in them. A good Muslim businessman should be guided by God's commandments and his conscience as a human being to execute legal and ethical actions towards others (Hashim, 2009).

The present study attempts to shed some light on OCB from the Islamic perspective in the Malaysian context. It is expected to be among the pioneering

research works that explores OCB from Islamic Perspective (i.e. in-depth study). The research is guided by the following research questions; (1) What is the relationship between Islamic spirituality dimension of Taqwa and OCB from Islamic perspective (OCBIP) in the business organizational context? (2) What is the relationship between Islamic social responsibility dimension of Taqwa and OCB from Islamic perspective (OCBIP) in the business organizational context?

The next sections will discuss the literature review highlighting the OCBIP, Taqwa concept which consist of two main dimensions of Islamic spirituality (IS) and Islamic Social Responsibility (ISR), methodology which highlights PCA and SEM analysis, then findings and recommendations for further research.

LITERATURE REVIEW

Islamic Spirituality (IS) and Islamic Social Responsibility as dimensions of Taqwa

As captured in the works of Kamil (2012) and Kamil, Alkahtani, and Sulaiman (2011), Kamil, Sulaiman, Osman-Gani and Ahmad (2012), Taqwa consist of two main dimensions of Islamic Spirituality (IS) and Islamic Social Responsibility (ISR). Operationally, IS is defined as the activities that Muslims do at all places and at all times in organizations, in ways that are in line with the Islamic teachings and principles, such that one constantly strives towards seeking the pleasure of Allah and His Guidance, whereas ISR is defined as anything that Muslims do in organizations that bring about mutual respect, mutual coexistence and development of mankind, the organization and us, with the constant remembrance of Allah (Dhikrullah) and seeking His pleasure (Kamil, 2012, Kamil et al., 2011 and Kamil et al., 2012).

In other words, as IS tends to strengthen the bond between man and Allah, ISR tends to strengthen the bond of society, thus, between man and man, man and nature, as well as man and entire universe. The comprehensiveness of the Taqwa construct is thus, envisioned to be holistic, engulfing most present concepts that are captured in Western literature, such as corporate social responsibility.

In an empirical study, Kamil et al. (2011) discussed the components of Islamic Spirituality (IS). According to the authors, Islamic spirituality in the business organizational context is explained by four (4) main components consisting of; Rituals (Ibadat), Forgiveness/Repentance (Al afw), Belief (Iman) and Remembrance of Allah (Dhikrullah). Similarly, another empirical confirmatory study by Kamil et al. (2012) captured five (5) components that explain the Islamic social responsibility (ISR) construct. According to the authors, these components include; Integrity, Emotional control, Fulfilment of covenant, Justice and Truthfulness. All these dimensions have been studied extensively in contemporary literature with regard to their importance in almost every society. For Integrity for one, it is quite prevalent in most ethical codes of almost all established disciplines, including ethical journalism (Akoje & Abd Rahim,

2014). Social responsibility in general as a construct has been emphasised by contemporary researchers in terms of its importance to the nation and the world large. For instance, Babatunde and Akinboboye (2013) in their research, captured that “social issues deserve moral considerations of their own and should head managers to consider the social impacts of corporate variables in decision-making” (p. 57). In view of these contentions, the present research attempts to investigate the impacts of social responsibility construct on OCBIP. According to Islamic management scholars, social responsibility is considered as one of the two main dimensions of Taqwa (Kamil et al., 2012).

ORGANIZATIONAL CITIZENSHIP BEHAVIOUR FROM ISLAMIC PERSPECTIVE (OCBIP)

The dependent variable is OCB from Islamic perspective (OCBIP). The operational definition of OCB from Islamic perspective is the individual discretionary actions in accordance with the Sharicah that individuals portray in organizations in order to seek *falāh* or *riḥallah* (pleasure of Allah) by the protection of the *maqāsid* (objectives) of the Sharicah; the protection and preservation of the five *ḥarūriyyat* (necessities) (i.e. protections of religion, life, wealth, reason/intellect and progeny), *ḥājjiyyat* (complementary) and *taḥsiniyyat* (embellishments). With reference to an empirical study, the OCBIP measurement model in the business organizational context is explained by four (4) components; Altruism (*Al-Eethaar*), Civic virtue (*Qayam al-muwatwanah*), Advocating high moral standards (*Da’wah*) and Removal of harm (*Raf’al haraj*) (Kamil, Sulaiman, Osman-Gani, & Ahmad, 2014).

The basic proposition of this framework is that employees’ level of Taqwa is a determinant or enabling factor to portray OCBIP. Since both the dependent (OCBIP) and the independent (Taqwa) variables consisting of IS and ISR, are based on the Islamic core belief system, this study is valid for Muslim employees only. However, non-Muslim employees and managers will benefit from the findings of the study as it will give them much insight into understanding and appreciating the belief system of their Muslim co-workers. This can boost togetherness and yield better mutual co-operation and understanding at the workplace.

The theoretical framework for the present study is captured in Figure 1.0 below.

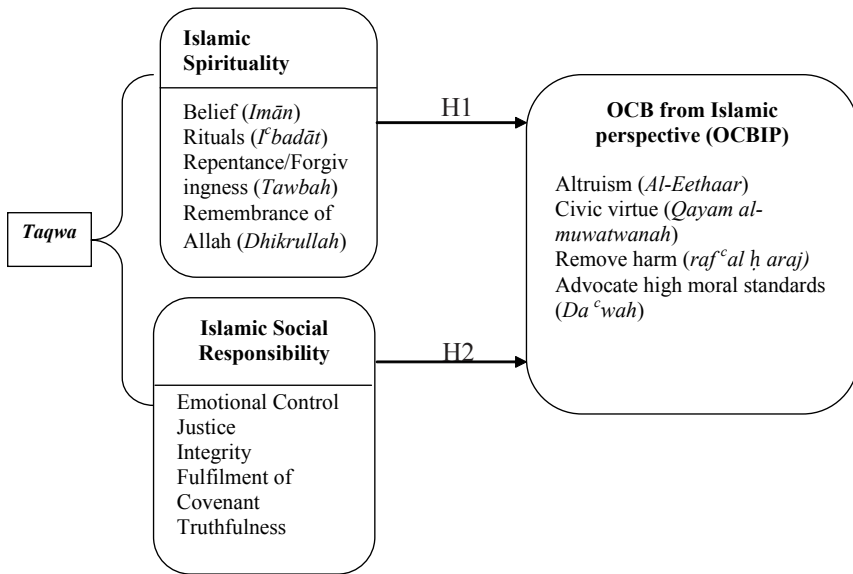

Fig 1.0 Theoretical framework

HYPOTHESES OF THE STUDY

H1: There will be a direct significant relationship between Islamic Spirituality (IS) and OCBIP.

H2: There will be a direct significant relationship between Islamic Social Responsibility (ISR) and OCBIP.

METHODOLOGY

Research Design

The research design employs a primary data approach by utilizing a set of structured questions formatted in nominal, ordinal, ratio, and interval scales. The research adopts a cross-sectional study approach whereby data is gathered once from the survey. The study is conducted in a natural environment of the business organization with the researcher not interfering with the normal flow of work. The study looked at organizational settings where employees are reacting to their own experiences and these reactions as held by Alexander and Ruderman (1987) may be different from those made in simulated situation.

Research Approach

This research aims to establish and verify the hypothesized relationships

between employees' Taqwa components (Islamic Spirituality and Islamic Social Responsibility) and OCBIP in an organizational context. Therefore, the Muslim employee is the unit of analysis for this study.

Sample and Sampling Procedure

The study was conducted on a disproportionate stratified random sampling of 50 business organizations in Malaysia. Malaysia was chosen because of some salient reasons; (1) Malaysia is one of the few Muslim nations that maintain and upholds Islamic values and culture in all its governmental sectors (Hashim, 2009); and (2) As per the 2000 Population Census, approximately 60.4 percent of the total population in Malaysia are Muslims, with the ethnic Malays being 100 percent Muslims.

Also, according to the 2010 world Muslim population report by Kettani (2010), the southeastern Asia region consists of eleven countries with a total population of 590 million, out of which 40.0% or 236 million are Muslims. And out of this 236 million Muslims, 17 million originate from Malaysia, making it the second Muslim populous nation in the region after the highest Indonesia with 205 million Muslim population. With full continued support from the Malaysian government, this seems to suggest, that Islamic values and culture governs employees' attitudes and behaviors in most organizations in Malaysia. Similarly, this contention was echoed by Lynn-Sze, Yusof and Ahmad (2014) that Malaysia is a multicultural and multi-ethnic society whereby "intercultural communications occur pervasively among people of different races and ethnicities in Malaysia" (p. 131). This seems to suggest that although the majority of the workforce in Malaysia comprises Muslims, the entire workforce are living in harmony and mutual coexistence. Thus, Muslim and non-Muslim employees alike could extract some benefits from the findings of the study.

The survey was conducted during the 2011/2012 academic session of the school year. The respondents of this study were Muslim employees of companies (businesses). The unit of analysis is the Muslim employee. The population frame was made available by cross-checking the listings of companies in Malaysia. The respondents of the main study were selected by using disproportionate stratified random sampling procedure. Random sampling has a higher probability of obtaining a representative sample than any method of sampling.

However, in order for the researcher to confine to a group of respondents appropriate for the study (Muslim employees), stratification of respondents was employed. The stratification technique is adequate for the current study, since the aims of the study are to answer research questions that are targeted to a subgroup (i.e. Muslim employees) within the population (employees). Owing to the fact that some strata are too small or too large with regard to the total number of Muslim employees in companies in Malaysia, a disproportionate sampling procedure is employed by the researcher.

According to Sekaran and Bougie (2010), redistribution of the numbers in the strata in disproportionate sampling might be considered more appropriate

and representative for a study that suspects variability within strata of respondents, than proportionate sampling design. Therefore, this study employs a disproportionate stratified random sampling technique. Precisely, the study aims to collect data from all Malaysian Muslim employees who work in business organizations or companies in Malaysia.

The Questionnaire, Variables and Measurements

This study requires the measurement of three main variables, namely; Islamic Spirituality (IS) (independent variable), Islamic Social Responsibility (ISR) (independent variable), and OCB from Islamic perspective (OCBIP) (dependent variable).

The scale by Kamil (2012) was adopted for the present study. Kamil's (2012) IS scale consist of 17 items, ISR consist of 29 items, and OCBIP consist of 31 items. Kamil's (2012) scale was adopted for this study owing to its high Cronbach alpha of more than 0.7. As well, quite a number of other researchers have employed Kamil (2012) scales of IS, ISR and OCBIP in their studies.

The questionnaire comprises a Likert scale ranging from 1 (Never) to 7 (Always). It captures IS items such as "I supplicate Allah whenever I face difficulty in my work" and "I apologize for my mistakes when I realize them at work". The scale captures ISR items such as "I am not afraid to tell the truth" and "I tend to be more forgiving with my co-workers". As well, OCBIP items are captured, such as "I participate actively in organizations' meetings" and "I encourage my co-workers to work diligently to develop the organization". All individual items show good internal consistency as evidenced by psychometric properties with Cronbach alphas of more than 0.7.

Specification of the hypothesized model

The hypothesized structural model included 13 manifest variables and three measurement models. The first measurement model was a latent variable OCBIP, and was identified by the four indicators; (1) Altruism; (2) Civic virtue; (3) Advocating high moral standards (Da cwah); (4) Removal of harm (Raf cal □araj). The second measurement model was a latent variable (IS) dimension of Taqwa, identified by the four observed variables (indicators); Rituals (Ibādāt), Forgiveness/Repentance (Al acfw), Belief (Imān) and Remembrance of Allah (Dhikrullah). The third measurement model was a latent variable (ISR) dimension of Taqwa, identified by the five observed variables (indicators); Integrity, Emotional control, Fulfillment of covenant, Justice and Truthfulness. The model hypothesized a causal relationship between the two exogenous latent variables of IS and ISR on the endogenous variable of OCBIP.

Using AMOS (Version 18.0), the results of skewness and kurtosis showed that there was no serious violation of normality assumption in each measurement model (i.e. skewness values were negative and less than 0.1). Also from the AMOS text output, the indices of the Mahalanobis distance (observations farthest from the centroid) showed that there was no case of any outlier. Accordingly,

these results allowed the use of the structural equation model to examine the two hypotheses.

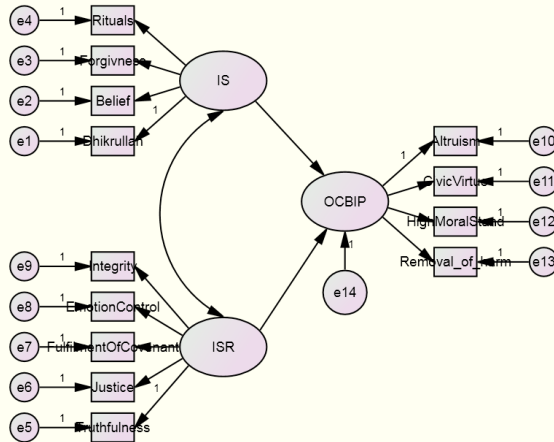

Fig 2. The Hypothesized model

Estimation of the Hypothesized Model

They hypothesized model was estimated by using AMOS (Version 18.0) adopting the Maximum Likelihood (ML) estimation on the data collected from the sample of 405 Muslim employees ($n=405$). The results of the model were assessed using the goodness-of-fit indices and reasonableness of parameter estimates. The squared multiple correlations (SMC) of the indicators were also computed. According to Tabachnick and Fidell (2007), SMC is interpreted as the reliability of the variables in the analysis and as the proportion of variance in the endogenous variable that is accounted for by the exogenous variable.

Moreover, the study estimated Cronbach's Alpha to show the internal consistency of indicators for each sub-construct in the OCBIP model. The inter-variable correlations were also assessed and it was found that all measures were statistically significant.

The results from the SEM structural model showed that the χ^2 was statistically significant [$\chi^2(62) = 326.855, p=0.000$] indicating that the hypothesized model was rejected. In other words, there were statistical inconsistency between the hypothesized model and the observed data. Also, the Normed chi square (CMIN/DF) which is an attempt to reduce the sensitivity of chi-square to the sample size, was found to be 5.272, thus, beyond the recommended ≤ 3.0 value.

The comparative fit index (CFI) was .875, indicating a lack of satisfactory fit index for the hypothesized model in relation to the uncorrelated model. The Turker-Lewis Index (TLI) was .843, less than the required value (.90). The root mean square error of approximation (RMSEA) also showed lack of fit (.109) for the hypothesized model. For a good fitting model, RMSEA should be close to zero (0).

Conversely, the parameter estimates of the hypothesized model as shown in Figure 3 did not show any offending estimates (offense-free). All path coefficients were positively directed with reasonable magnitude. The causal path between ISR and OCBIP was statistically significant at 0.001, but the second path index of IS and OCBIP was not significant.

Despite the practical importance of the path between ISR and OCBIP, the four indices (i.e. χ^2 , CFI, TLI and RMSEA) showed that the hypothesized model did not fit the data well, and the path coefficient between IS and OCBIP was not statistically significant. This, thus, calls for the need to look for the best fit indices for the model.

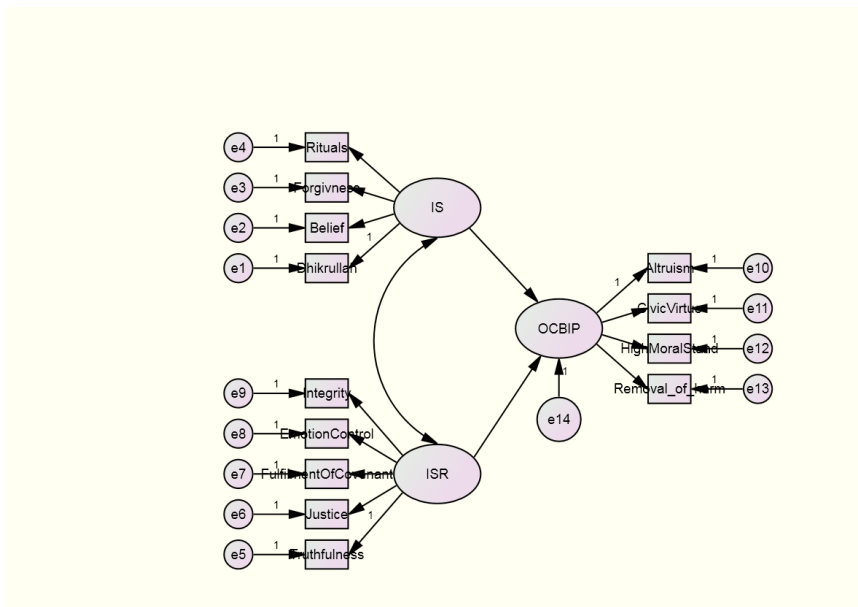

Fig 3. Fit Indexes and Parameter Estimates of Hypothesized Model

To address the inadequacy, it was realized that the path between ISR and Integrity was also not significant (i.e. first indicator of ISR in this model). The squared multiple correlations (SMCs) also confirmed that ISR explains only 0.4% of the variance in Integrity. These statistical justifications necessitated the exclusion of the Integrity sub-construct (observed variable) in the revised model.

Furthermore, modification indices were examined. Six covariances between errors were allowed in the revised OCBIP model. The correlations were established in a pair of error terms in order to produce a better fit. This is, however, justified methodologically (using AMOS) and theoretically.

First is the covariance established between error 2 (Belief) and error 10 (Altruism) which shared a certain amount of measurement error (i.e. covariance .46). The measures of the two variables seemed to be related to both “possessing a strong belief in Allah” and “helping people”. Second, the covariance between error 3 (Forgivingness/Repentance) and error 10 (Altruism) shows a positive relationship with a magnitude (.33) indicating that there is a strong relation between “being kind and forgiving or passing over others’ faults” with “being helpful to co-workers”. This is justified in the Qur’an (3:159) where Allah revealed to the Prophet Muhammad (p.b.u.h.) how to help, and seek for the help of his companions, especially in matters of decision making. Allah says “And by the Mercy of Allah, you dealt with them gently. And had you been severe and harsh-hearted, they would have broken away from about you; so pass over (their faults) and ask (Allah’s) Forgiveness for them; and consult them in affairs. Then when you have taken a decision, put your trust in Allah, certainly, Allah love those who put their trust (in Him)” (Qur’an, 3:159).

Third, the interrelated errors between error 4 (Rituals) and error 12 (Advocating high moral standards) were positively related (.28), implying that “employees who conduct their rituals (□alāh, zakāh, fasting the month of Rama□an and □ajj) in the right manner” have the tendency to “advocate high moral standards” in their organizations. Fourth, the link between the two errors, i.e. error 1 (Remembrance of Allah) and error 10 (Altruism) showed a direct positive association (.40) of such behavioral aspects of the two variables, indicating that “being cognizant with seeking Allah’s pleasure at all times” is related to “helping people”. This is held true as confirmed in the Qur’an “(saying): We (the pious and righteous) feed you seeking Allah’s Countenance only. We wish for no reward, nor thanks from you” (Qur’an, 76:9).

Fifth, in a similar manner, the covariance (.26) between error 1 (Remembrance of Allah) and error 2 (Belief) shows the positive relations between the two behavioral measures of “having a strong belief in Allah” and “being cognizant with seeking Allah’s pleasure at all times”. Last but not least, sixth covariance between error 6 (Justice) and error 8 (Emotional control) were also positively related (.27), which seem to imply that “employees who have the tendency to effectively control their anger” may be “just to themselves and will also show justice to others”. This is justified by the verse in the Qur’an “O you who believe! Stand out firm for Allah as just witnesses; and let not the enmity and hatred of others make you avoid justice. Be just: that is near to piety; and fear Allah. Verily, Allah is Well-Acquainted with what you do” (Qur’an, 5:8).

Revised Hypothesized Model

As shown in Figure 4, the goodness-of-fit indices of the revised hypothesized

model was sharply improved as compared to that of the hypothesized model. Although the χ^2 was statistically significant [$\chi^2 (45) = 158.795, p=.000$], thus, indicating that there were statistical discrepancies between the observed covariance matrix of the sample (observed data) and the implied covariance matrix of population (revised hypothesized model), the Normed chi-square (CMIN/DF) showed a good fit for the revised model, with an index less than 3 (i.e. 2.64), supporting the consistency of the data to the revised model. The statistical significance of the χ^2 statistic (suggesting the rejection of the model) may be due to the large sample size (n=405).

Moreover, the measure of RMSEA was .064, which is below the recommended cut-off of $RMSEA \leq .07$ for the complexity (i.e. 28 total variables, 12 observed variables and 405 sample size) of this revised model (Hair et al., 2010, Kline, 2011). Thus, RMSEA of .064 indicates lack of any significant difference between the covariance matrix of the sample and the covariance matrix of population. In other words, the revised model adequately fitted the data.

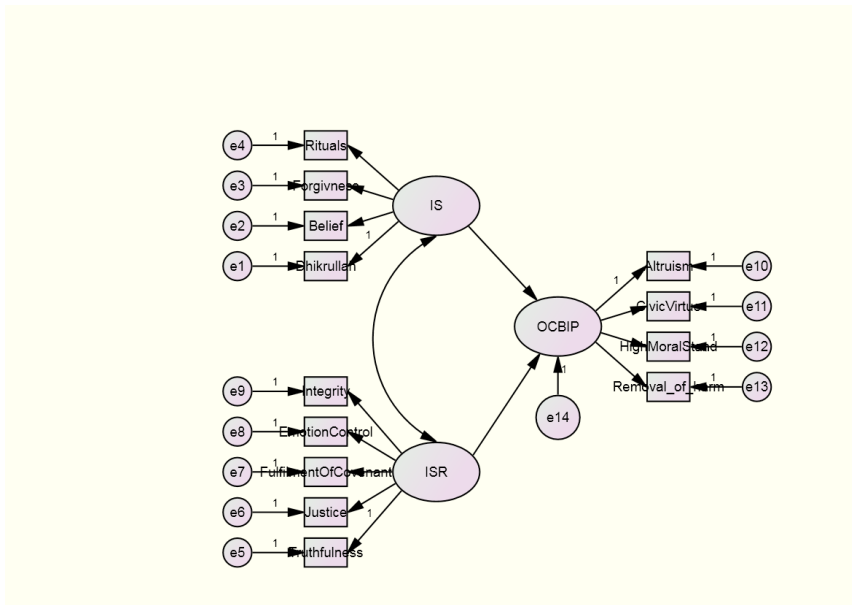

Fig 4.0 Revised OCBIP Model showing Path Coefficients and Goodness-of-fit

In addition, the CFI (.964) and TLI (.948) of the revised model also show adequacy of the model fit, adding more evidence to support the goodness of fit of the revised OCBIP model. The squared multiple correlations (SMCs) also offered high reliabilities ranging from .768 (OCBIP) to .152 (Rituals). Furthermore, the AMOS (Version 18.0) text output did not provide any further

suggestion to modify the revised model.

The parameter estimates also supported the adequacy of the revised model. As shown in Figure 4.0, the path coefficient between ISR and OCBIP was quite high (.88) and statistically significant; indicating that for each one unit increase in ISR, there will be a .44 unit increase in OCBIP, controlling other variables in the model. This result indicates that the Islamic Social Responsibility (ISR) characteristics substantially determine the OCBIP construct.

However, the path between IS and OCBIP was not statistically significant, indicating that the Islamic Spirituality (IS) of Muslim employees is not a determinant of their OCBIP performance. Perhaps, the insignificance of the relation between IS and OCBIP may be explained by the *ḥadīth* of the Prophet (p.b.u.h.) which says “the best amongst the believers (i.e. persons with high IS) are those with good manners (generous behavior)”. Good mannerism captured in this *ḥadīth* is a function of ISR. Thus, this *ḥadīth* is held true considering the relation between ISR and OCBIP, but not between IS and OCBIP.

In addition to this, the Prophet (peace be upon him) has also mentioned in another *ḥadīth* saying “a believer (someone with high IS) may steal, may fornicate, and may commit other sins, but the believer will never lie”. Lying, as mentioned in this *ḥadīth* is negative function captured in the “Truthfulness” sub-construct of ISR. This leads us to the belief that, a person who possesses high IS, may not necessarily exhibit OCBIP if he/she does not possess good manners (generous behavior).

Furthermore, the correlation between IS and ISR showed a strong magnitude (.81) and was statistically significant. This implies that the two components of *Taqwa* (i.e. IS and ISR) are strongly related and supported one another. In addition to this, the standardized regression weights for the observed variables showed practical importance. With the exception of the relation between IS with OCBIP (.001), all had values of more than 0.1. This evidence further confirms the consistency of the theoretical bases in terms of hypothesis 2, showing that Islamic Social Responsibility (ISR) has strong predictive power (.88) for OCBIP. However, hypothesis 1 was not supported; thus, the Islamic spirituality of employees does not influence their OCBIP behavior.

Comparison of the Revised Model with Alternative Models

The research looked at alternative models in order to establish the usefulness of the revised model. The first alternative model fixed the causal relationship between IS and OCBIP at zero. The second alternative model constrained the reciprocal relationship between IS and ISR at zero.

It is worth noting from Table 1, that the first alternative model did not show encouraging goodness of fit indices; the χ^2 value was statistically significant ($\chi^2 = 329.276$, $p=.000$), which implies that there was different between the two matrices for the observed sample and implied population. Other indices also did not show reasonable fit, i.e. CFI (.875), TLI (.845) and RMSEA (.102).

The second alternative model compared to the first alternative model, showed

poor fit; ($\chi^2 = 552.065, p=.000$). It was also noted that the χ^2 value was higher than that of the first alternative model and the revised model. Other indices also showed lack of adequate fit to the model, i.e. CMINDF (8.763), CFI (.769), TLI (.714) and RMSEA (.139).

In conclusion, it was noted that the revised model showed the best fit indices in comparison with the first and second alternative models. The χ^2 statistic was significant. As well, other fit indices showed good fits; (CMINDF = 2.640, CFI = .964, TLI = .948).

The revised model indicated that Islamic Social Responsibility (ISR) has a strong predictive power (.88) on OCBIP, and explained 77% of variability in the endogenous variable.

Table 1.0
Goodness-of-fit Indices, Parameter Estimates, Variance Explained for Two Alternative Models and the Revised Model

Model Comparison			
Fit Indices	Alternative 1	Alternative 2	Revised Model
Model Chi-square (χ^2)	329.276	552.065	118.795
P value	.000	.000	.000
CMINDF (χ^2/df)	5.227	8.763	2.640
CFI	.875	.769	.964
TLI	.845	.714	.948
RMSEA	.102	.139	.064
Standardized parameter estimation/parameter correlation			
OCBIP → IS	Constrained to zero	.41	.00
OCBIP → ISR	.89	.73	.88
IS ↔ ISR	.83	Constrained to zero	.81
Variance Explained (R ²)	.79	.70	.77

DISCUSSION OF FINDINGS

Relationship between IS and OCBIP

Taqwa consist of Islamic spirituality and Islamic social responsibility dimensions. Islamic spirituality in turn consists of Belief (Imān), Rituals (Ibādāt), Repentance/ Forgiveness (Tawbah/Al acfw) and Remembrance of Allah (Dhikrullah).

Islamic social responsibility consists of Patience (□abr), Emotional Control, Forgiveness, Sadaqah, Justice, Integrity, Fulfilment of Covenant, Remembrance of Allah (Dhikrullah), Guarding Chastity, Truthfulness and Love of the family.

According to the Qur'an, people with Taqwa will receive Allah's help and guidance in difficult situations and in ease. Allah says in the Qur'an "Truly, Allah is with those who fear Him (keep their duty unto Him), and those who are Muhsinun (good-doers) (16:128). According to Al-Helali (2000), enjoining a good act to a person and producing quality work is an indication of high level of Taqwa. In addition to this, Allah says in the Qur'an "Verily, the earth is Allah's. He gives it as a heritage to whom He wills of His servants; and the (blessed) end is for the pious and righteous person" (Qur'an,7:128). As held by Sayd Qutob (1982), success (falāh) is the natural fruit of Taqwa. This falāh is a worldly success as well as in the hereafter.

As regards Islamic spirituality, Habil (1989) posits that spirituality results in more knowledge. More knowledge leads to better decisions. Also, according to Ali (2005), in Islam the spiritual need helps in maintaining self-confidence and assurance during difficulties and hardship. Hawa (2004) argued that Islamic spirituality is capable to produce the complete Muslim who would worship Allah and also be a valuable member to his society through his kindness. Based on this theoretical rationale, the first hypothesis was constructed as follows: that there will be a significant positive relationship between Islamic Spirituality dimension of Taqwa and the propensity to exhibit OCB from Islamic Perspective (OCBIP). Although SEM results show good fit indices, the hypothesis was not supported.

Perhaps, the insignificance of the relation between IS and OCBIP may be explained by the □adith of the Prophet (p.b.u.h.) which says "the best amongst the believers (i.e. persons with high IS) are those with good manners (generous behavior)". Good mannerism captured in this □adith is a function of ISR. Thus, this □adith is held true considering the relation between ISR and OCBIP, but not between IS and OCBIP.

In addition to this, the Prophet (p.b.u.h.) has also mentioned in another □adith saying "a believer (someone with high IS) may steal, may fornicate, and may commit other sins, but the believer will never lie". Lying, as mentioned in this □adith is negative function captured in the "Truthfulness" sub-construct of ISR. This leads us to the belief that, a person who possesses high IS, may not necessarily exhibit OCBIP if he/she does not possess good manners (generous behavior).

Another point worth mentioning in support of the IS' statistical insignificance is found in the works of Prominent Muslim scholars such as Imam Ibn Taymiyah. In Ibn Taymiyah's (2006) works in the book (Al-Imān Al-'Wsat), he mentioned that faith (Imān) [which is a component of IS in this study] is not complete by mere belief in the heart and utterance by the tongue. It has to be completed by action. This, thus, suggests increasing ISR by putting faith into practice. This is also supported by Raba (2001) who mentioned that the effect of valid faith

leads human beings to performing good deeds, such as being heedful, truthful, disciplined and sincere. It can be noted that truthfulness, sincerity (Integrity in this study) are all ISR components but not IS.

Relationship between ISR and OCBIP

An employee who is patient, exercises a lot of emotional control, forgives the shortcomings of his/her co-workers and customers, gives sadaqah, is Just, has a sense of integrity for his/her image, fulfils his/her covenant, observes constant remembrance of Allah (Dhikrullah) in all his/her activities, guards against his/her chastity, is truthful and loves his/her family, will have high propensity to exhibit Islamic OCB. Based on this theoretical rationale, the second hypothesis was constructed; that the social responsibility of Muslim employees as described in the five components of the Islamic social responsibility (ISR) dimension of Taqwa influences employees' performance of organizational citizenship behavior from Islamic perspective (OCBIP), by exhibiting its components of Altruism, Civic virtue, Advocating high moral standards and Removal of harm. The study offered methodological and theoretical evidence in support of this hypothesis.

Structural equation modeling (SEM) of OCBIP showing good fit indices has supported the hypothesis (Fig. 4.0). Also, the path coefficient of the OCBIP model demonstrated that ISR influence employees' OCBIP performance (i.e. standardized coefficient = .856, critical ratio = 5.956, $p = 0.001$). All other sub-constructs in the model had statistical significant estimates with the exception of the path estimates between IS and OCBIP, and the path estimates between Integrity and ISR. The path estimates between Integrity and ISR was not statistically significant (i.e. standardized coefficient = .125, critical ratio = 1.193, $p = .233$) as shown in the hypothesized OCBIP model (Fig. 3.0) which necessitated its exclusion in the revised model.

This finding that ISR leads to Muslim employees' OCBIP performance seems to replicate the findings of Al-Amar (2008) who proposed the Interpersonal Characteristics of the Muslim Personality (ICMP) construct. From her study, Al-Amar (2008) mentioned that the ICMP consist of; (1) Interpersonal characteristics composed of four elements of Islamic morality (cooperation, jihad, reconciliation and voluntary charity); (2) Self-purification which contains three elements (truthfulness, fulfilling promises, and trust-justice); and (3) Endurance characteristics which contains two elements (steadfastness and forgiveness). Using SEM, Al-Amar (2008) found statistical significant relationship between ICMP and Western OCB construct.

The finding of the present study with regard to ISR's statistical significant relationship with OCBIP is also consistent with the Islamic literature. Particularly, the results support the notion that Muslims who do good deeds towards themselves and others (i.e. having high ISR) develop a faith that guides them towards, honesty, trustworthiness and justice towards themselves as well as other for the sake of gaining Allah's reward (Mohsen, 2007). Although

caution was warranted when it comes to comparing the results of this study (from Islamic perspective with different context) with previous Western OCB studies (emanating from the Western value system), it is worth mentioning the likelihood of moral dimensions of personality, such as fairness, justice, trust etc. to have produced significant relationships (e.g. Moorman & Fetter, 1990; Podsakoff et al., 1990; Podsakoff et al., 2000).

CONCLUSION

The study answered the research hypotheses by using surveyed data drawn from 405 Muslim employees in business organizations in Malaysia.

Using Structural Equation Modelling (SEM), the goodness-of-fit indices addressed the two research hypotheses, in which it was hypothesized that IS and ISR are determinants of OCBIP. The findings potentially supported the theory that the ISR of Muslim employees is a determinant of their OCBIP performance, but not enough evidence was available to support the theory that employees' IS is a determinant of their OCBIP performance.

The findings of this study have implications for policy makers in the human development sector of government organizations and for human resource managers and professionals in private business organizations. Particularly, human resource development (HRD) scholars and professionals may use the findings of this research to justify their efforts in designing, developing, and implementing appropriate learning and performance improvement interventions, so that Islamic spirituality and social responsibility (IS and ISR) could be enhanced continuously among Muslim employees. This could lead to attaining high ethical and moral values of employees that might control many undesirable behaviors (greed, corruption, disobedience, etc.) of employees that are negatively affecting contemporary organizational performance.

In addition, non-Muslim professionals and employees can also take relevant initiatives in this regard, whereby the research findings will provide new insights to the people of other faiths in properly understanding Muslim employees' values and expectations. The increased understanding of the values and organizational perspectives of people from various faiths will help in developing increased tolerance among members of increasing multi-cultural, multi-religious organizations of today's changing social and business environments.

In future, this research could be replicated in other contexts (other Muslim majority countries with different socio-cultural values), and study the impact of several contextual variables in this regard. Since this is the first research on the contemporary issues of religion and OCB, findings from this study may trigger more research interests among the current and future scholars who might be interested in this field.

ABOUT THE AUTHORS

Naail Mohammed Kamil is a prominent scholar on Islamic Management with his contributions particularly on Organizational Behaviour, Spirituality, Social Responsibility, and Ethics from the conventional and Islamic perspectives. He is a Senior Lecturer at the Faculty of Business, Accountancy and Management, SEGi University in Malaysia. He can be contacted at naaikamil@segi.edu.my

Mohamed Sulaiman is an Emeritus Professor, currently attached to the Graduate School of Management, IIUM. He was former Razak chair professor, Ohio University, USA, former chair, Islamic management research group, IIUM, former Dean, school of management, Universiti Sains Malaysia (USM) and a former head of department, IIUM. He can be contacted at prof.mohamed.sulaiman@gmail.com

Sugumaran Selladurai is a Senior Lecturer and current head of department at the Faculty of Business, Accountancy and Management, SEGi University in Malaysia. He has more than 20 years of experience in practice and in academia combined. His research and teaching interest include Active Teaching and Learning, Corporate Social Reporting (CSR) and Environmental Accounting. He can be contacted at sugumaran@segi.edu.my

Nadhira Khalid is a freelance fiction published writer and freelance professional translator (English – Bahasa Indonesia) and editor with over 15years of experience. She is currently pursuing her Masters Degree in Management at the Graduate School of Management, International Islamic University Malaysia. She can be contacted at nadhirakhalid@yahoo.com

REFERENCES

- Ali, A. J. (2005). *Islamic perspective on management and organization*, Edward Elgar Publishing Limited.
- Ahmad, K. (1997). Islamic ethics in the changing environment for managers. *Malaysian Management Review*, 32, 1-6.
- Akoje, T. P., & Abd Rahim, M. H. (2014). Development of journalism ethics: A comparative analyses of codes of ethics in Nigeria, United Kingdom, United States of America, India and Russia. *Jurnal Komunikasi [Malaysian Journal of Communcation]*, 30 (2), 231-238.
- Ahmad, K. (2008). *Management from Islamic perspective: principles and practices*. Kuala Lumpur: IIUM Press.
- Babatunde, K. A., & Akinboboye, S. (2013). Corporate social responsibility effect on consumer patronage - management perspective: Case study of a telecommunication company in Nigeria. *Jurnal Komunikasi [Malaysian Journal of Communcation]*, 29 (1), 55-71.
- Blau, P. (1964), *Exchange and Power in Social Life*, Wiley, New York, NY.
- Habil, A. (1989). *Traditional esoteric commentaries on the Qur'an*. London: The Crossroad Publishing Company.
- Hair, J. F., Black, W. C., Babin, B. J., Anderson, R. E., & Tatham R. L. (2010). *Multivariate data analysis*. New Jersey: Pierson Hall.
- Kamil, N. M., Sulaiman, M., Osman-Gani, A., & Ahmad, K. (2010). Implications of Piety (Taqwa) on Organizational Citizenship Behavior (OCB) from Islamic Perspective: A study of Professionals in Southeast Asia. 9th International Conference of the Academy of HRD (Asia Chapter) (pp. 166-181). Shanghai: Academy of Human Resource Development, Institute of vocational and adult education, East China Normal University, China.
- Kamil, N. M., & Sulaiman, M. Osman_Gani, A. M., & Ahmad, K. (2011). Effects of Spirituality and Social Responsibility on Job Performance: A conceptual analysis from religious perspectives. AHRD International Research Conference in the Americas. Chicago: Academy of Human Resource Development.
- Kamil, N. M., Al-Kahtani, A. H., & Sulaiman, M. (2011). The components of spirituality in the business organizational context: The case of Malaysia, *Asian Journal of Business and Management Sciences*, 1 (2), 166-180.
- Kazmi, A. (2004). *A Preliminary Enquiry into the Paradigmatic Differences among the Conventional and Islamic Approaches to Management Studies*. Unpublished Paper, Malaysia: IIUM.
- Kettani, H. (2010). 2010 World Muslim Population. *Proceedings of the 8th Hawaii International Conference on Arts and Humanities*, Honolulu, Hawaii, January 2010, (pp. 1-61). Hawaii.
- Kline, R. B. (2011). *Principles and practices of structural equation modeling*

(3ed.). New York: The Guilford Press.

- Moorman, R.H. (1991). Relation between organizational justice and organizational citizenship behaviors: do equity perceptions influence employee citizenship? *Journal of Applied Psychology*, 76(6) 127-33.
- Lynn-Sze, J. C., Yusof, N. & Ahmad, M. K. (2014). The relevance of Confucian values to leadership communication. *Jurnal Komunikasi [Malaysian Journal of Communication]*, 30 (special issue), 129-144.
- Moorman, R.H., Niehoff, B.P. and Organ, D.W. (1993). Treating employees fairly and organizational citizenship behavior: sorting the effects of job satisfaction, organizational commitment, and procedural justice. *Employee Responsibilities and Rights Journal*, 6, 209-25.
- Monfared, S. Y., Mousavi, S. H., Sajjadi, S. N., & Heidary, A. (2011). Assessing organizational citizenship behaviour among physical education teachers in Zanjan-Iran. *Procedia - Social and Behavioral Sciences* , 15, 3661-3664.
- Organ, D. W. (1977). A Reappraisal and Reinterpretation of the Satisfaction-Causes- Performance Hypothesis. *Academy of Management Review*, 2, 46-53.
- Organ, D. W. (1990). The Motivational Basis of Organizational Citizenship Behavior. In B. M. Staw & L. L. Cummings (Eds.). *Research in Organizational Behavior*, 12, 43-72. Greenwich, CT: JAI Press.
- Organ, D. W. & Konovsky, M. (1989). Cognitive Versus Affective Determinants of Organizational Citizenship Behavior. *Journal of Applied Psychology*, 74(1), 157-164.
- Organ, D.W. (1988). *Organizational Citizenships Behavior: The Good Soldier Syndrome*. Lexington Books, Lexington, MA.
- Organ, D.W. & Ryan, K. (1995). A meta-analytic review of attitudinal and dispositional predictors of organizational citizenship behavior. *Personnel Psychology*, 48, 775-802.
- Organ, D. W. (1997). Organizational citizenship behavior: It's construct clean-up time. *Human Performance*, 10, 85-97.
- Organ, D. W., Podsakoff, P. M., & MacKenzie, S. B. (2006). *Organizational citizenship behavior: Its nature, antecedents, and consequences*. Thousand Oaks, CA: Sage Publications.
- Podsakoff, P.M., MacKenzie, S.B. and Hui, C. (1993). Organizational citizenship behaviors as determinants of managerial evaluations of employee performance: a review and suggestions for future research, in Ferris, G.R. and Rowland, K.M. (Eds). *Research in Personnel and Human Resources Management*, JAI Press, Greenwich, CT, 1-40.
- Podsakoff, P. M., MacKenzie, S. B., Moorman, R. H., & Fetter, R. (1990). Transformational Leader Behaviors and Their Effects on Follower's Trust in Leader, Satisfaction, and Organizational Citizenship Behavior. *Leadership Quarterly*, 1(2), 107-142.

- Podsakoff, P. M., Ahearne, M., & MacKenzie, S. B. (1997). Organizational citizenship behavior and the quantity and quality of work group performance. *Journal of Applied Psychology*, 82, 262–270.
- Podsakoff, P. M., & MacKenzie, S. B. (1994). Organizational citizenship behaviors and sales unit effectiveness. *Journal of Marketing Research*, 3, 351–363.
- Podsakoff, P. M., & MacKenzie, S. B. (1997). Impact of Organizational Citizenship Behavior on organizational performance: A review and suggestion for future research. *Human Performance*, 10 (2), 133- 152.
- Podsakoff, P., Mackenzie, S., Paine, J. and Bachrach, D. (2000). Organizational citizenship behaviours: a critical review of the theoretical and empirical literature and suggestions for further research. *Journal of Management*, 26 (3), 513-63.
- Podsakoff, N. P., Whiting, S. W., Podsakoff, P. M., & Blume, B. D. (2009). Individual- and Organizational-Level Consequences of Organizational Citizenship Behaviors: A Meta Analysis. *Journal of Applied Psychology* , 94 (1), 122-141.
- Raba, A. M. (2001). Major personality in the Qur'an. Kuala Lumpur: Noordeen.
- Sayd Qutob (1982). *Fi zilāl al-qur'an [Beneath the shadow of the Qur'an]*, Vol. (1), Bayrut: Dar al-shoruq.
- Sekaran, U. (2003). *Research methods for business: a skill-building approach* (4th ed.). Singapore: John Wiley & Sons.
- Sekaran, U., & Bougie, R. (2010). *Research methods for business: a skill-building approach* (5th ed). Haddington: John Wiley & Sons.
- Vineet Kaul (2012). Globalization And Gender Issue. *Jurnal Komunikasi, Malaysian Journal of Communication*. V 28 (2) 2012.
- Wan Idros Wan Sulaiman & Maizatul Haizan Mahbob (2012). Analisis Keberkesanan Pembinaan Pasukan (Team Building): Impak Ke Atas Sumber Daya Manusia. . *Jurnal Komunikasi, Malaysian Journal of Communication*. V 28 (2) 2012.
- Yuslinda Mat Yassin & Hasmah Zanuddin, (2012). Visibility Of PM Najib's 100 Days In Office: A Framing Approach Of His Political Branding Identity. *Jurnal Komunikasi, Malaysian Journal of Communication*. V 28 (2) 2012.